

EN **Assembly instructions**

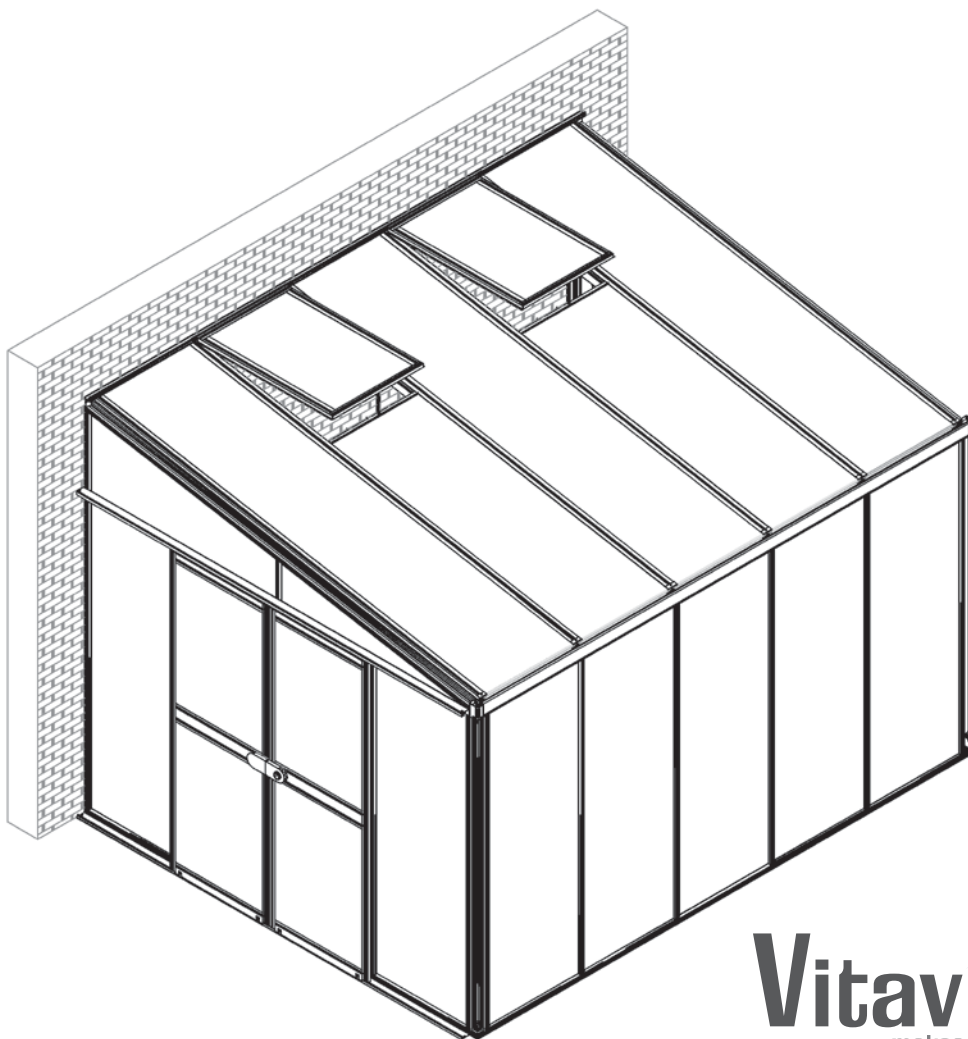











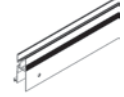

Vitavia
- makes living grow

HELENA
7000, 8600, 10200, 11900

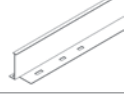
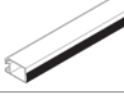

Item No.	Part	Sect. Ref.	Size mm	Quantity			
				7000	8600	10200	11900
1002		8	M6	2	2	2	2
1006		4b 5 8	3.5x6	8	14	14	20
1402		8	36	2	2	2	2
1403		8	20	2	2	2	2
1405		8	15	2	2	2	2
1409		8	20	2	2	2	2
1412		8	M6x22	2	2	2	2
1415		8	1750	2	2	2	2
2002		6b	4.2x38	2	2	2	2
2003		6b	Ø 8	2	2	2	2
2271		6a	37	4	4	4	4
3002		8	M6	2	2	2	2
6056		4b	47	2	4	4	6
6070		5 8	Ø 13.5	192	210	224	242
6090		7b	57000 61000 66000 70000	1 - - -	- 1 - -	- - 1 -	- - - 1
7048		4b	M6x80	2	4	4	6
7050		1 2 3 7b	M6x42	85	90	95	100

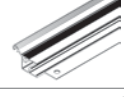
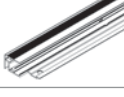
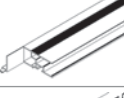
Item No.	Part	Sect. Ref.	Size mm	Quantity			
				7000	8600	10200	11900
7052		1-8	M6x12	93	102	107	116
7053		1-8	M6	192	210	224	242
7055		4b	M6x10x14	2	4	4	6
7090		5	324	1	2	2	3
7290		6a	12000	1	1	1	1
7301		2	2602.9	1	1	1	1
7302		3	2602.9	1	1	1	1
7304		1	2657.4	1	-	-	-
7305			3286.4	-	1	-	-
7306			3915.4	-	-	1	-
7307			4544.4	-	-	-	1
7310		1	1801	2	2	2	2
7311		1 2 3	1801	8	9	10	11
7312		1	1915	2	2	2	2
7313		2 3	1911.5	2	2	2	2
7314		1	2586	1	-	-	-
7315			3215	-	1	-	-
7316			3844	-	-	1	-
7317			4473	-	-	-	1
7321		2	2537.7	1	1	1	1
7322		3	2537.7	1	1	1	1
7323		7a	592	4	5	6	7
7324		7a	2586	1	-	-	-
7325			3215	-	1	-	-
7326			3844	-	-	1	-
7327			4473	-	-	-	1

Item No.	Part	Sect. Ref.	Size mm	Quantity			
				7000	8600	10200	11900
7330		4b	2583	3	4	5	6
7331		4b	218	3	4	5	6
7332		6a	9000 x 10	1	1	1	1
7333		7a	572	4	5	6	7
7334		4a	2654	1	-	-	-
7335			3283	-	1	-	-
7336			3912	-	-	1	-
7337			4541	-	-	-	1
7340		4a	2590	1	1	1	1
7341		4a	2590	1	1	1	1
7342		7a	45	2	2	2	2
7343		7a	56	3	4	5	6
7344		2	2310	1	1	1	1
7345		3	2310	1	1	1	1
7346		4a	224.5	1	1	1	1
7347		4a	224.5	1	1	1	1
7348		4a	93.5	4	4	4	4
7349		7a 8	3.9x10	15	20	23	28
7350		6a	20	4	4	4	4
7351		6b	2548	1	1	1	1

Item No.	Part	Sect. Ref.	Size mm	Quantity			
				7000	8600	10200	11900
7352		6a	653	1	1	1	1
7353		6a	653	1	1	1	1
7354		6a	574	1	1	1	1
7355		6a	574	2	2	2	2
7356		6a	1828	2	2	2	2
7357		6a	1828	1	1	1	1
7358		6a	1828	1	1	1	1
7359		8	2548	1	1	1	1
7360		6a	M6	4	4	4	4
7361		6b	1796	2	2	2	2
7362		6b	1222	1	1	1	1
7363		6b	1217	1	1	1	1
7364		6a	Ø 32	4	4	4	4
7365		5	598	1	2	2	3
7366		5	598	1	2	2	3
7367 (7391)		5	890	2	4	4	6
7368		4b	593	1	2	2	3

Item No.	Part	Sect. Ref.	Size mm	Quantity			
				7000	8600	10200	11900
7369		8	30	2	4	4	6
7370		8	71.35	1	1	1	1
7371		8	71.35	1	1	1	1
7372		7b	1819	8	9	10	11
7373		7b	1819	4	4	4	4
7374		7b	1819	2	2	2	2
7375		7b	462	1	1	1	1
7376		7b	462	1	1	1	1
7377		7b	2581	1	1	1	1
7378		7b	2581	1	1	1	1
7379		7b	240	1	1	1	1
7380		7b	240	1	1	1	1
7381		7b	618	10	11	12	13
7384		6a	574	1	1	1	1
7390		6b	M6x30	4	4	4	4
7391 (7367)		5	890	2	4	4	6
7392		6a	Ø 5/3	8	8	8	8

Item No.	Part	Sect. Ref.	Size mm	Quantity			
				7000	8600	10200	11900
7393		6a	M6x31	4	4	4	4
7395		4a 4b	Ø 12/6.5	5	6	7	8
7396		1 2 3 4a	16200 16800 17400 18100	1 - - -	- 1 - -	- - 1 -	- - - 1
7399		4b	M6x12	12	16	20	24
7400		6a	123	1	1	1	1
7401		6a	123	1	1	1	1
7402		6a	60	1	1	1	1
7404		6a	M4x10	8	8	8	8
7405		6a	M4x25	4	4	4	4
7407		7b	30	10	11	12	13
7409		7b	30	8	8	8	8
7411		4a	3.8 x 80	12	13	14	15
7412		4a 4b	3.8 x 60	14	15	16	17
7414 7415 7416 7417		4a	2654 x 15 3283 x 15 3912 x 15 4541 x 15	1 - - -	- 1 - -	- - 1 -	- - - 1
7421		4a	Ø6 X 80	12	13	14	15
7422		4a 4b	Ø6 X 60	14	15	16	17

Safety Warning

- PLEASE READ THESE INSTRUCTIONS CAREFULLY AND COMPLETELY BEFORE ASSEMBLING YOUR GREENHOUSE.
- Sharp edges and corners can cause injury. Always wear protective glasses, gloves, shoes and headgear when handling the aluminium profiles, glass and polycarbonate sheets. Broken glass is a safety hazard – always clear up immediately and dispose of with care.
- The product you have purchased is intended **only** for the growing of plants and should **only** be used for this purpose. When used for other purposes we will take no responsibility.
- It is recommended that this greenhouse is assembled by two people.
- When using a step ladder one person should steady it at all times whilst the other works.
- Should you encounter difficulties constructing this house or in positioning the polycarbonate sheets, please contact your retailer – **do not use force!**
- The green house must always be anchored.

Assembly Instructions

SITE SELECTION

Always try to select a sunny location, sheltered from the wind as much as possible.

IMPORTANT

Before assembling your new greenhouse, please check that all parts in the provided list are included. Please take each bundle out of the packaging in order to identify the parts better.

It is important that the opened bundles do not get mixed with one another.

If something is missing please contact your retailer.

Note - The UV-resistant side of the polycarbonate panes is indicated by a plastic folio or printing at the edge. **This side must face outside.**

NECESSARY TOOLS

Screw drivers (Normal and Crosshead PH2), Rubber Hammer, 1.8m ladder, 10 mm socket spanner or wrench, 10 mm combination spanner, craft knife, measuring stick, spirit level, Accu-drill with adjustable torque, Ø 20mm drill.

MAINTENANCE

The greenhouse should be thoroughly washed with a gentle detergent occasionally. Please check that the detergent used does not react aggressively with aluminium or plastic.

Ensure that the door tracks are cleaned regularly to avoid a buildup of debris

0. FOUNDATION

Important! The foundation must be exactly right angular and level. To achieve this you will require a spirit level and a right angle.

Note - If the distance between the two opposite corners is the same then the foundation is right angular.

For the erection of this greenhouse we suggest a solid foundation constructed from concrete, brickwork or stonework. If you have no experience with the construction of such a foundation please consult a company specialising in this work. Materials and tools for the preparation of the suggested foundation are not provided.

The suggested foundation allows the door to be assembled on any side of the greenhouse.

Foundations must extend down below the frost level.

Diagrams in a single frame show the view from inside the greenhouse. Those enclosed in a double frame show the view from outside the greenhouse.

1. FRONT ELEMENTS

Note - If the door will be assembled in the front of the house remove one of the middle bars (7311)ⓐ.

Push seal (7396) into the sill bar (7304 - 7307) and cut to fit both ends (1.1) (1.2).

Lay all of the parts, according to the model, on the floor and loosely connect by inserting bolts (7052) into the bolt channels.

Take care that the eave angles (7314 - 7317) are pushed into the corner of both corner bars (7310) (1.3) (1.4) and that corner bars (7310) and middle bars (7311) sit correctly on the assembly edge on the eave angle (1.9) (1.12).

Assemble diagonal bars (7312) on both sides (1.3) (1.4) (1.10) (1.11). At the sill loosely attach using bolt (7050). (7050) will be removed during glazing (section 7b).

2. PLAIN GABLE END

Note - If the door will be assembled on this side of the house remove middle bar (7311)ⓐ.

Push seal (7396) into sill bar (7301) and wall

bar (7344) and cut to fit the ends (2.1) - (2.4).

Lay all of the parts on the floor and loosely connect by inserting bolts (7052) into the bolt channels.

Assemble end bar (7321) into the recess in wall bar (7344) (2.5) (2.6) and then (7344) onto sill bar (7301) (2.7) (2.8).

Assemble middle bars (7311) (2.9) (2.10), noting the assembly edge on the eave angle (1.9).

Assemble diagonal bar (7313) (2.5) (2.11) (2.12). At the sill loosely attach using bolt (7050). (7050) will be removed during glazing (section 7b).

3. DOOR GABLE END

Note - If the door is to be assembled on another side then assemble the (7311)ⓐ, which was previously removed, in position ⓐb.

Assemble all parts as in Section 2.

4a. CONNECTING THE SIDE ELEMENTS

(4a.1) shows the 4a assembly if the door is to be in the front of the house.

Push seal (7396) into the ridge bar (7334 - 7337) and cut to fit the ends. Insert brush seal (7414 - 7417) into the guide in the ridge bar. (4a.2) (4a.3).

Loosely prepare bolts (7052) and nuts (7053) in sill bars (7301) and (7302) as shown in (4a.4). Lower corner bars (7310) fitting the bolt heads of (7052) into the bolt channels of (7310) (4a.5).

Connect end bars (7321) and (7322) to corner bars (7310) ensuring they are pushed against the eave angle bar (4a.6).

Assemble the ridge bar (7334 - 7337), roof corner bars (7340) (7341) and wall bars (7344) (7345) (4a.7) (4a.8) using plate (7348). Assemble roof corner bars onto the eave angle (4a.9) (4a.10). Ensure that the roof corner bars sit correctly on the assembly edge on the eave angle (4b.5).

Assemble end middle bars (7346) (7347) to the end bars and the roof corner bars using plate (7348) (4a.11).

Position the assembled frame against the wall on the prepared foundation, check that it is level and drill Ø6 holes through the prepared holes in (7301), (7302), (7304 - 7305), (7344) and (7345) on the wall and foundation.

Insert wall plugs (7421) or (7422) into the holes and connect loosely to the foundation and wall using screws (7411) and (7412) (4a.12).

4b. ROOF MIDDLE BARS

Loosely prepare (7052) and (7053) in the ridge bar and slide middle bars (7330) into position fitting the bolt heads of (7052) into the bolt channels of (7330) (4b.1) (4b.2).

Insert (7052) into the bolt channel in (7330) at the eave and lower onto the eave angle using washer seal (7395) and nut (7053) (4b.3) (4b.4). Ensure that (7330) sit correctly on the assembly edge on the eave angle (4b.5) and that the small hole on the outside of (7330) is at this end.

Drill Ø6 holes through the prepared holes in (7334 - 7337). Insert wall plugs (7422) into the holes and loosely connect the ridge bar to the wall using screws (7412) (4b.6).

Adjust the frame until it is completely right angular and tighten all screws (7411) and (7412) and nuts (7053). **Please do not over tighten.**

Connect roof vent fixers (6056) onto the roof vent sill bars (7368) using screws (1006) (4b.7) (4b.8).

Assemble completed sill bars (7368) in the desired sections where the roof vents will later be positioned. Insert cross dowel (7055) into sill bar (7368) and bolt (7048) through roof middle bars (7330) (4b.9) (4b.10).

(Note - Roof vents cannot be positioned in the corner roof sections and must have at least one complete section between them.)

Assemble corner braces (7331) between each side middle bar (7311) and roof middle bar (7330) by inserting cropped head bolts (7399) into the bolt channels (4b.11) (4b.12).

5. ROOF VENTS

Connect roof vent bottom bar (7366) to side bars (7367) (5.2) (5.3).

Slide pane D into the glazing channels (5.5) in the assembled parts (5.4).

Loosely prepare (7052) and (7053) in roof vent top bar (7365) and slide onto (7367) fitting the bolt heads of (7052) into the bolt channels and the glazing into the glazing channels (5.6) (5.7).

Check that the roof vent is right angular before tightening all bolts.

Please do not over tighten.

Connect roof vent lifter (7090) to (7366) using two screws (1006) (5.8) (5.9).

Connect plastic nut caps (6070) by pushing them onto all nuts (7053) (5.10).

6a. SLIDING DOORS

Insert brush seal (7332) into the guides in the door bars (7352) (7353) (7355) (7356) (7357). (6a.2).

Loosely assemble wheels (7364), using spacers (7392) on each side of the wheel, bolt (7393), jump clip (7350) and lock nut (7360), onto door bottom bars (7355) (6a.3).

Connect (7355) with door side bars (7357) or (7358) (6a.3) (6a.7a).

Assemble door middle bars (7354) or (7384) with lock parts (7400), (7401) and (7402) using bolts (7404). Connect to door side bars (7357) or (7358) using bolts (7052), nuts (7053) and bolts (7405) (6a.4) (6a.5) (6a.8).

Connect door top bars (7352) or (7253) to door side bars (7357) or (7358) (6a.6) (6a.7b).

Slide panes G into the glazing channels in the assembled parts (6a.9).

Loosely prepare (7052) and (7053) in door side bars (7356) and slide onto (7355), (7354) or (7384) and (7352) or (7353) fitting the bolt heads of (7052) into the bolt channels and the glazing into the glazing channels (6a.9) (6a.10). Insert door guides (2271) into the top of both doors (6a.6).

Note - If you have chosen 4mm glass glazing then cut glazing seal (7290) to fit and press into the space in the glazing channels on the inside of the door to fix the glass in place (6a.11).

6b. DOOR FRAME AND STEP

Assemble door support (7362) onto the sill bar in the door opening using bolts (7390) (6b.1) (6b.2).

Tilt door wheel track (7351) to fit into the sill bar and lower into position (6b.3). Centre on the door opening and connect to the foundation using wall plug (2003) and screw (2002) (6b.4).

Connect door side frames (7361) to middle bars (7311). When in place connect to the top using bolt (7052) and nut (7053) (6b.5) - (6b.8).

At the bottom insert bolt (7052) into the channel on both sides of door step (7363) (6b.9) and slide the door step into place (6b.10)

(6b.11).

7. GLAZING OVERVIEW

Please sort the glazing according to your model size and glazing type before beginning. If you have chosen glass then panes E and F are identical on both sides.

Note - The UV-resistant side of the polycarbonate panes is indicated by a plastic folio or printing at the edge. **This side must face outside.** Loosen the film approximately 2cm at all edges of each pane before assembly. When the assembly of all panes is finished completely remove all film from the panes.

7a. ROOF GLAZING / EAVE

Slide the roof glazing into the guides in the roof profiles (7a.2) (7a.3). When two adjacent panes are in place, screw glazing stops (7342) or (7343) onto the roof profile between them using the prepared holes and self-drilling screws (7349) (7a.4) (7a.5). The panes should slide down to rest against these stops.

Angle the eave bar (7324 - 7327) into the eave angle (7a.7) and turn it down to rest against the eave angle. Connect it to the eave angle using bolts (7052) from outside and nuts (7053) inside the house (7a.8).

Insert glazing spacers (7323) over the inside edge of the eave angle (7a.9). If you have 10mm glazing then position spacer (7333) into the groove in (7323), resting against the pane. Fix in place using the prepared holes and self-drilling screws (7349) (7a.9) (7a.10). 16mm glazing does not require spacer (7333) (7a.11).

7b. SIDE GLAZING

If glazing with 4mm glass, press glazing rubber (6090) onto the aluminium profiles (7b.2) and cut to length. **Note** - With Polycarbonate the glazing rubber is not required.

Through the positioning of the (7050) bolt head in the different guides in the glazing capping's, it is possible to glaze the greenhouse with 4mm, 10mm or 16mm panes (7b.2). Prepare bolts (7050) in each glazing capping as shown (7b.3).

For 10mm glazing prepare 1 spacer (7407), in the middle / top of each pane A (7b.4). Position each glazing pane A into the frame and connect the vertical capping's (7372), (7373) or (7374) loosely with nuts (7053).

Lift pane A 15mm and connect capping's (7381) loosely under the pane.

Note - The bolts (7050) used to hold the diagonal braces in sections 1, 2 and 3 should be replaced at this point (7b.8).

For 10mm glazing prepare 4 spacers (7409) onto each (7321) and (7322) (7b.5) (7b.6).

Position panes E and F.
Connect capping's (7377) or (7378) and then (7375) / (7379) or (7376) / (7380) loosely.

Tighten all nuts. **Please do not over tighten.**

Note - The vertical capping's can be best assembled when the bottom bolt is first inserted into the hole, then the middle and finally the top bolt. Ensure that the capping remains in contact with the sill bar.

8. FINAL STEPS

Insert eave plastic (7370) and (7371) in both ends of the eave bar (7324 - 7327) (8.1).

Note - It can help to pull the eave bar at the top edge, carefully away from the house so that the opening for the plastic becomes larger.

Take a drill not larger than Ø25mm and make a hole in the marked area inside parts (7370) and (7371) (8.2).

Insert cropped head bolt (1412) into the bolt channel at the bottom of corner bar (7310) and connect parts (1405) and (1409) with aluminium nut (1002) on both sides (8.3). Fit elbow (1402) onto the bottom of down pipe (1415) (8.6) and then connect this to the eave plastic (7370) or (7371) (8.11). Fit the down pipe clamp (1403) around the down pipe and connect to (1409) (8.4). Insert screw (1006) to fix the down pipe in place (8.5).

Slide the roof vent into the correct section from one end of the house (8.7). Attach the roof vent fixer (7369) using the prepared holes and self-drilling screw (7349) on both sides of the roof vent (8.8) (8.9).

Assemble door track (7359) into the door opening. Connect to (7321), (7322) or (7324 - 7327) by inserting bolts (7052) into the bolt channel on the outside of these bars and connect with nuts (7053) (8.10).

Include at both ends of door track bar (7359) bolt (7352) from outside and nut (3002) inside the door guide to prevent the door from sliding out of the track (8.10) (8.11).

Position the doors by inserting the plastic door guides (2271) into the guide in door track bar (7359) (8.12) (8.13) and then lower the wheels onto the door track on bar (7351) (8.13). Hook the door jump clips (7350) under the lip on (7351) and tighten the lock nuts (7360) (8.13).

Connect plastic nut caps (6070) by pushing them onto all visible nuts (7053) inside the building (8.14).

Note - It is recommended to include a bead of neutral silicone between the ridge bar and wall

from outside (8.9b). Neutral silicone is not provided.

FINISHING

If desired, it is possible to seal the greenhouse at the edges using neutral silicone. Silicone is not included.

Place the warning label inside the house.

Please check the tightness of all nuts and bolts 2 weeks after completing the assembly.

A full range of greenhouse accessories, to help you make the most of this product, is available from your stockist. Please inform yourself as to the possibilities.

SAFETY NOTICE

In the event of high wind conditions, close the doors and all vents.

In the event of heavy snowfall, clear the roof of the building or take suitable measures to support the roof. Heat the building in winter.

COMMENTS

For the complete protection of your new greenhouse, we advise you to include it in your **house insurance**. Please take note of possible building rules relating to the positioning of greenhouses.

Please stick the included greenhouse model label onto door bar (7352) or (7353) after successfully assembling this product. This information is important in the event that replacement parts are later required.

Please keep these assembly instructions in a safe place, for future reference!

Our policy is one of continuous improvement and we reserve the right to change the specifications without prior notice.

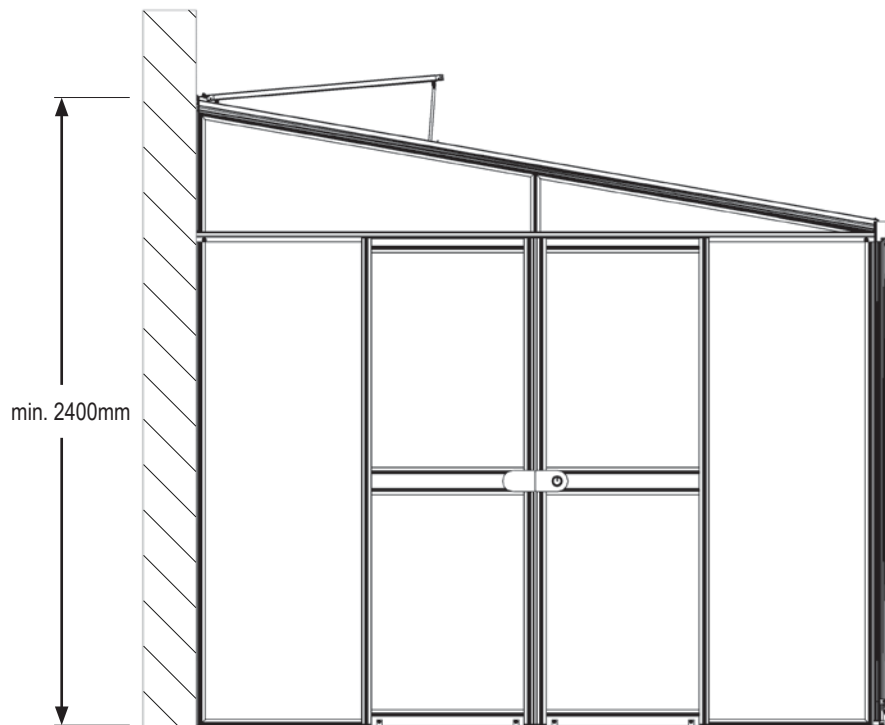
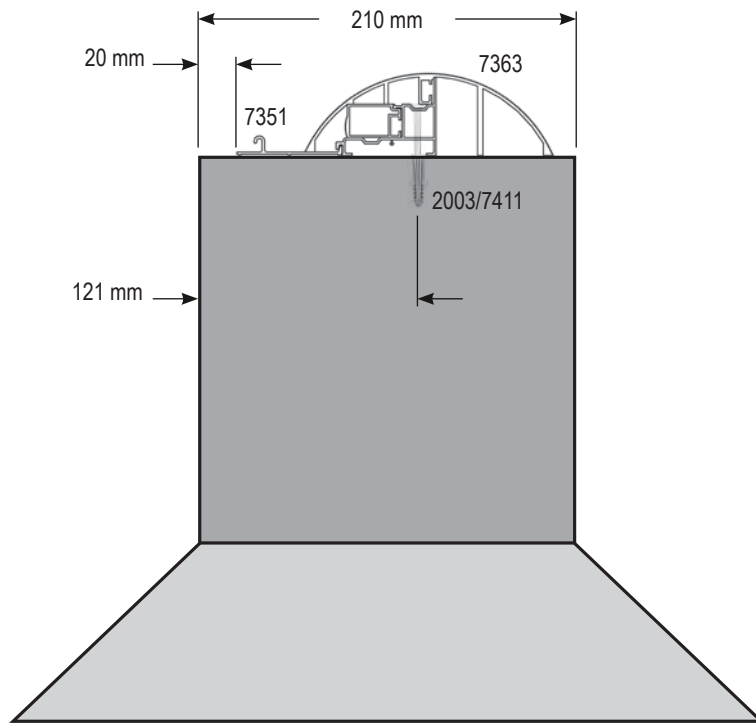
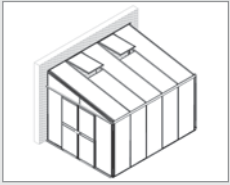

HELENA

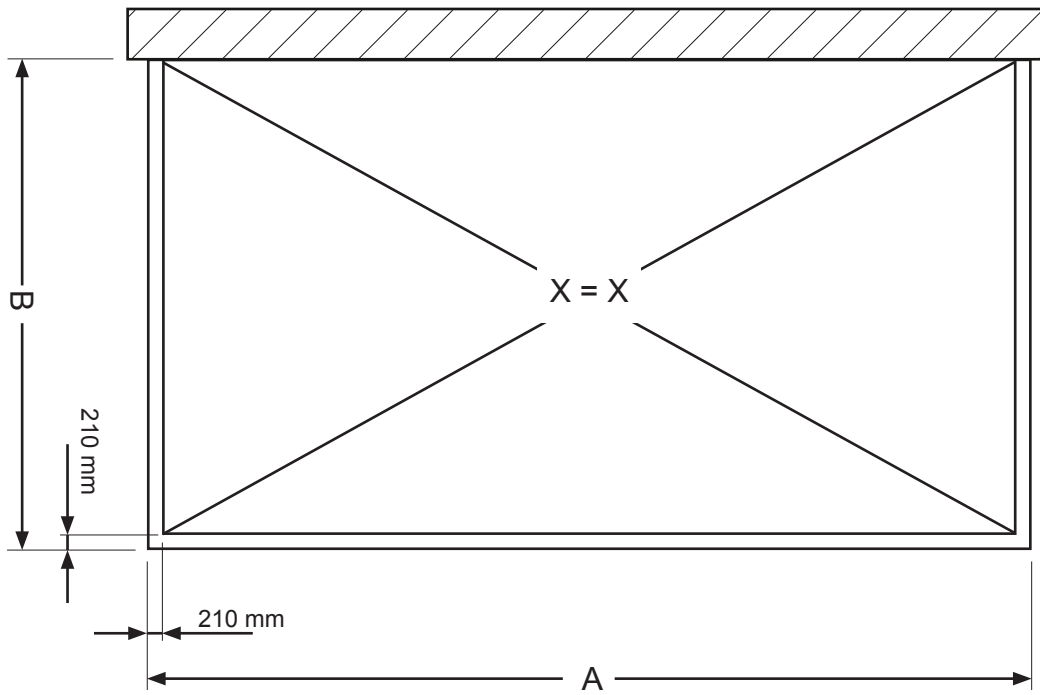

	7000	8600	10200	11900
A	2809 mm	3438 mm	4067 mm	4696 mm
B	2679 mm	2679 mm	2679 mm	2679 mm





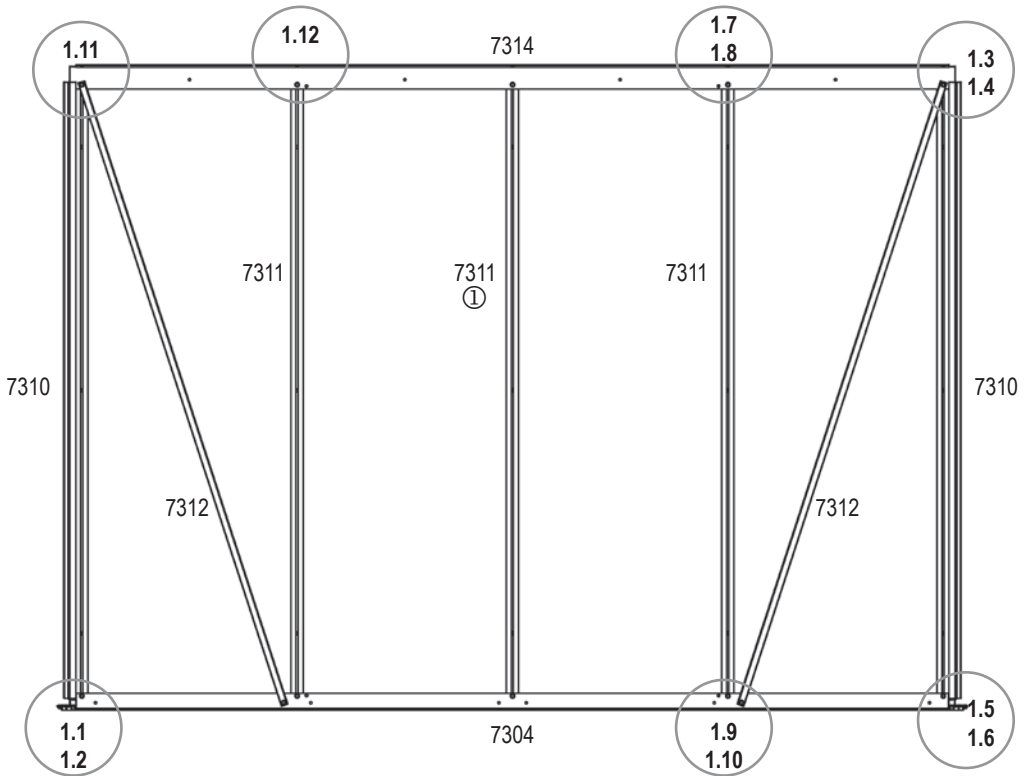



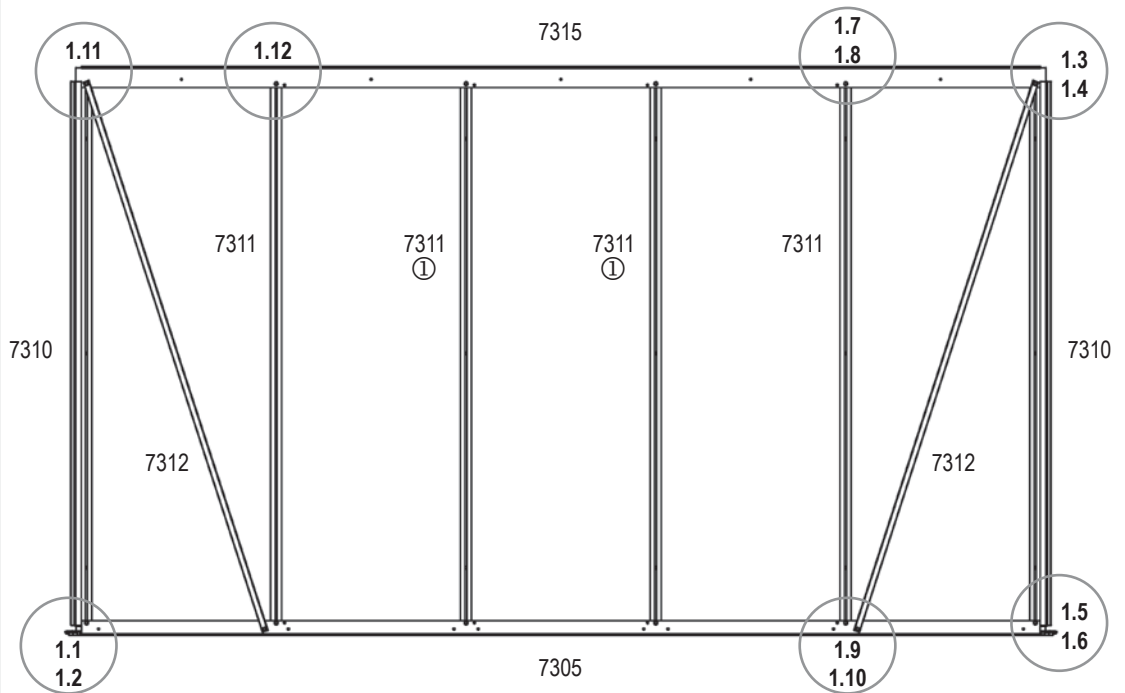

7000



8600



7000	8600	10200	11900
7050 			
2	2	2	2
7052 			
10	12	14	16
7053 			
12	14	16	18
			
7304	7305	7306	7307
1	1	1	1
7310 			
2	2	2	2
7311 			
3	4	5	6
7312 			
2	2	2	2
			
7314	7315	7316	7317
1	1	1	1
7396 			
1	1	1	1

HELENA

10200

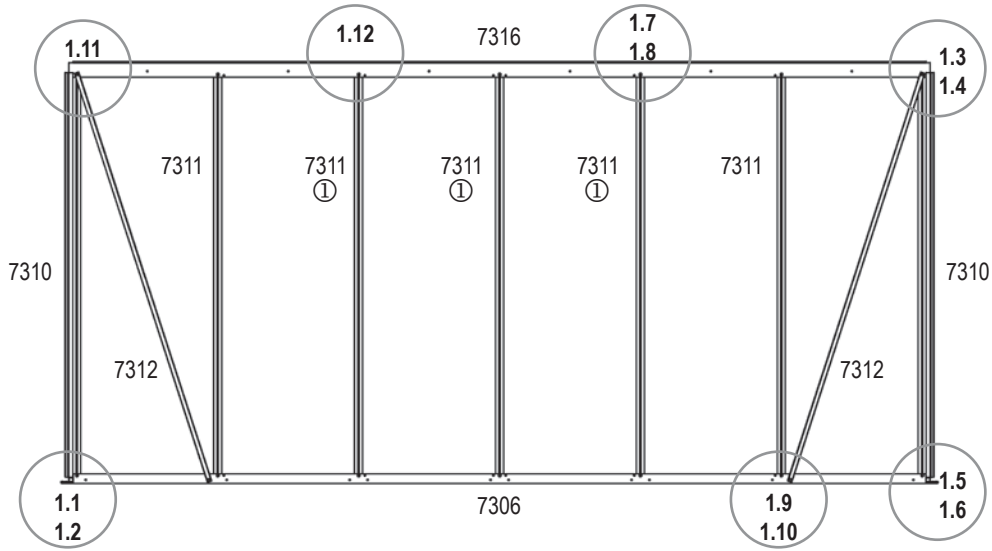

11900

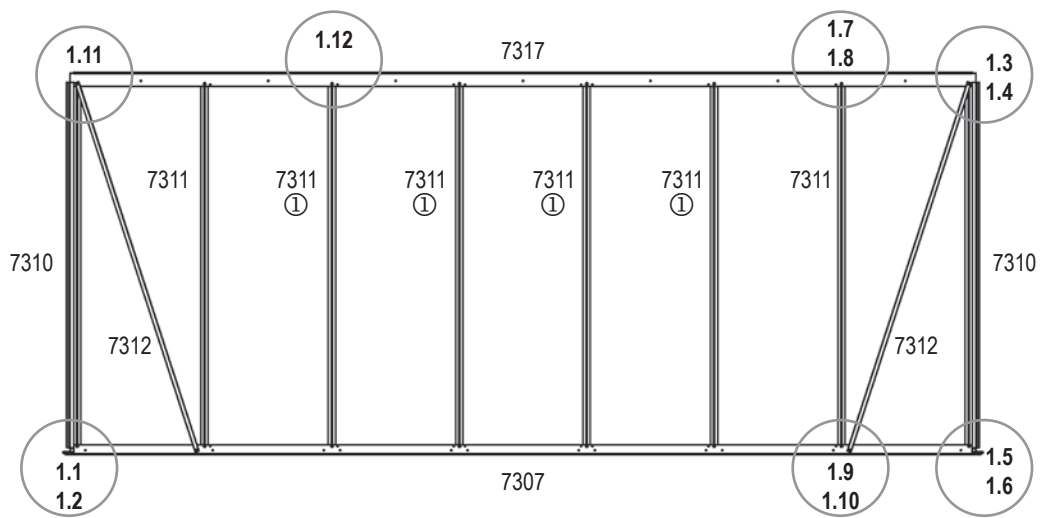

1

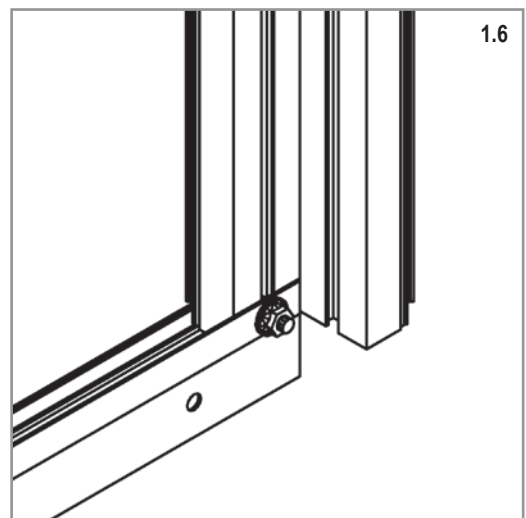
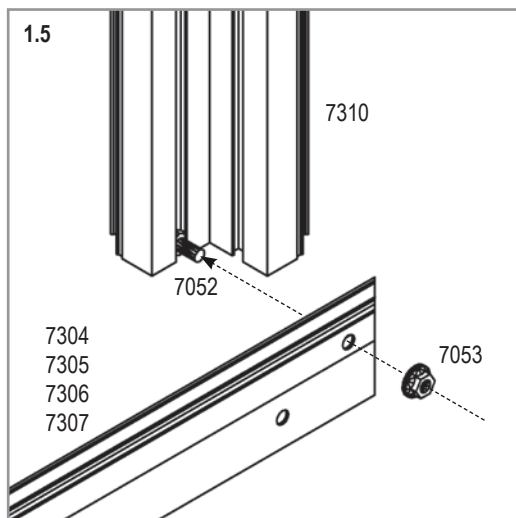
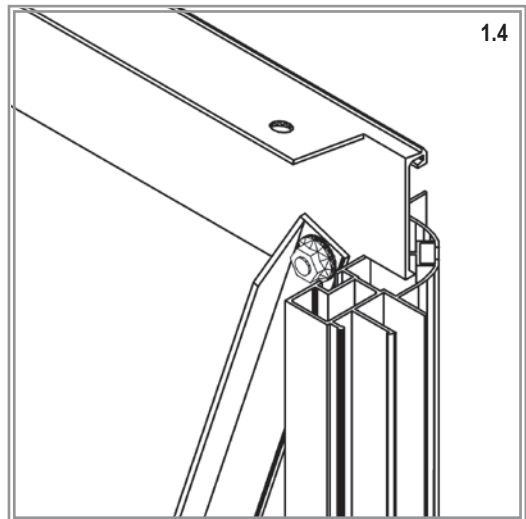
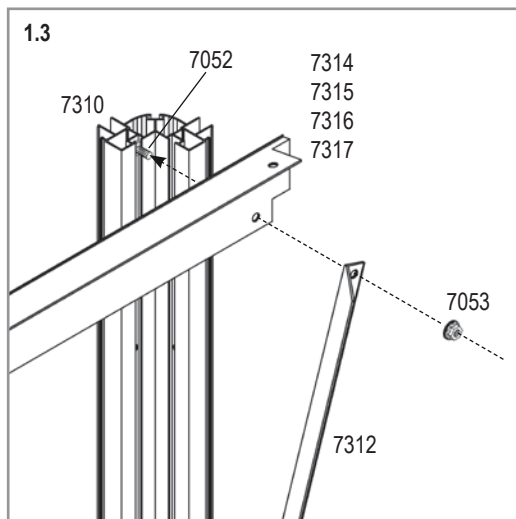
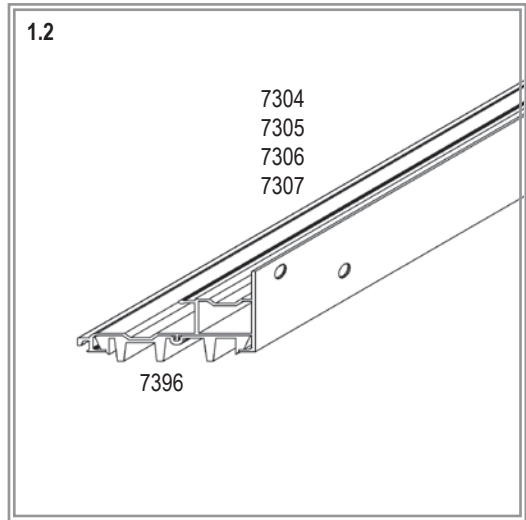
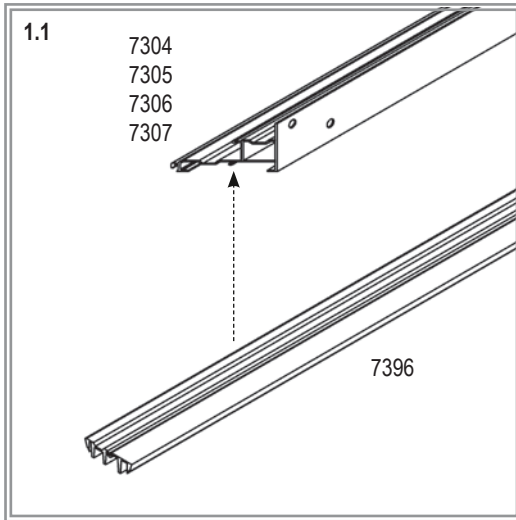

HELENA

1

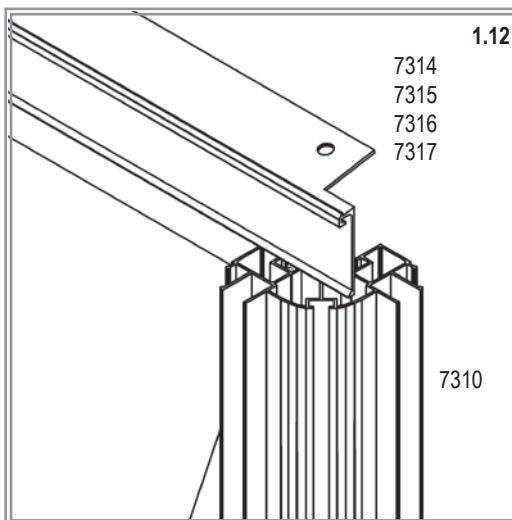
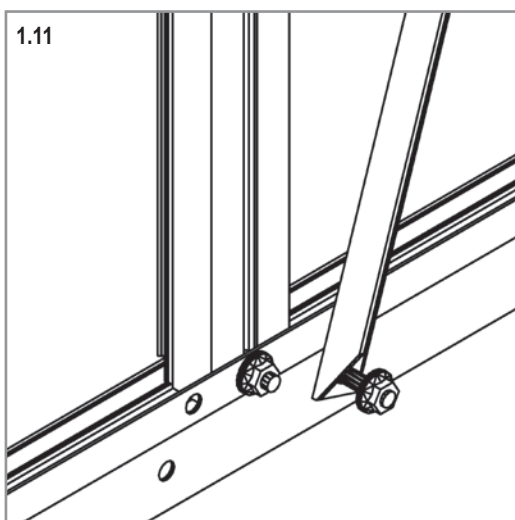
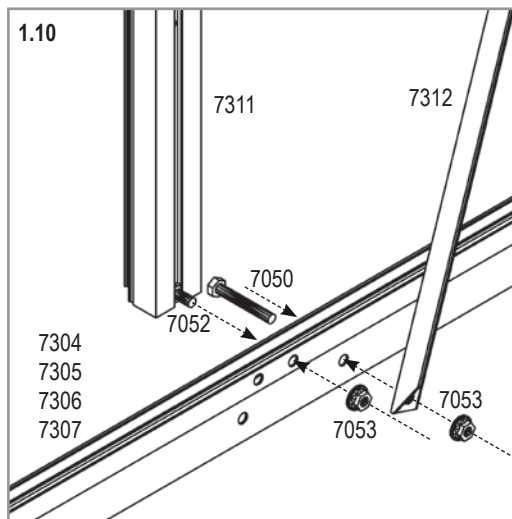
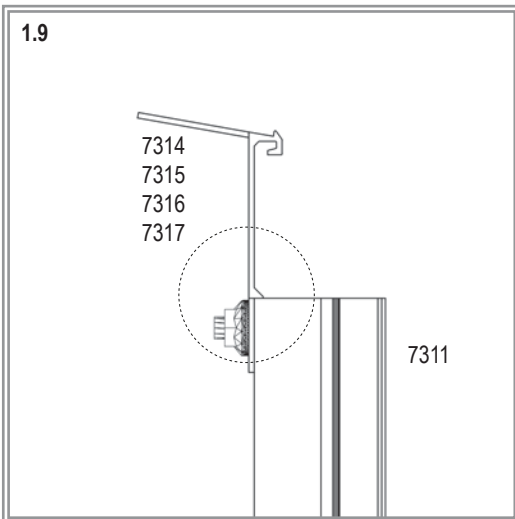
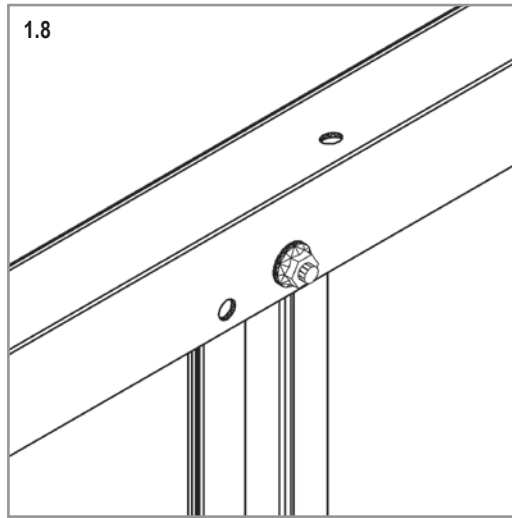
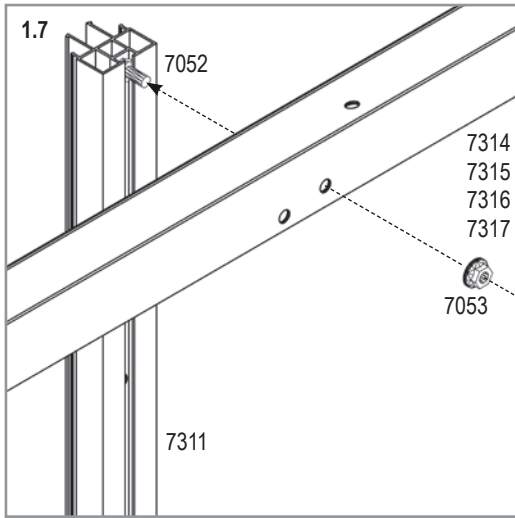

HELENA

2



	7000	8600	10200	11900
7050	1	1	1	1
7052	9	9	9	9
7053	10	10	10	10
7301	1	1	1	1
7311	3	3	3	3
7313	1	1	1	1
7321	1	1	1	1
7344	1	1	1	1
7396	2	2	2	2

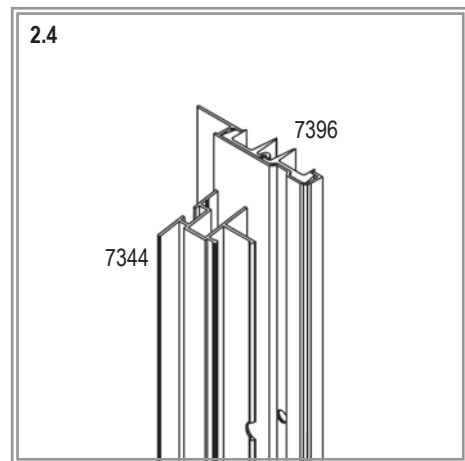
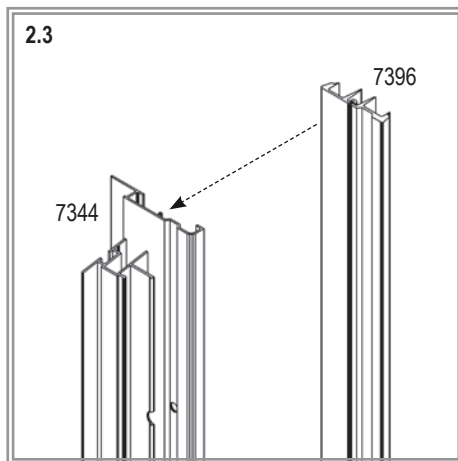
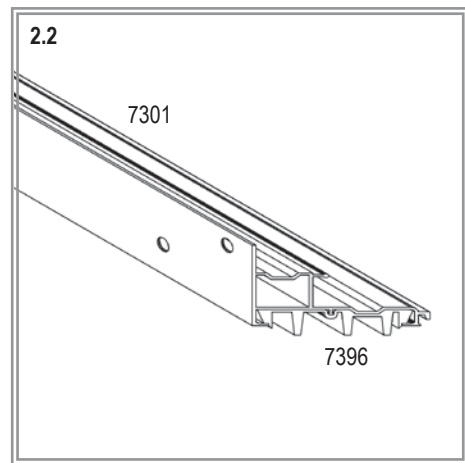
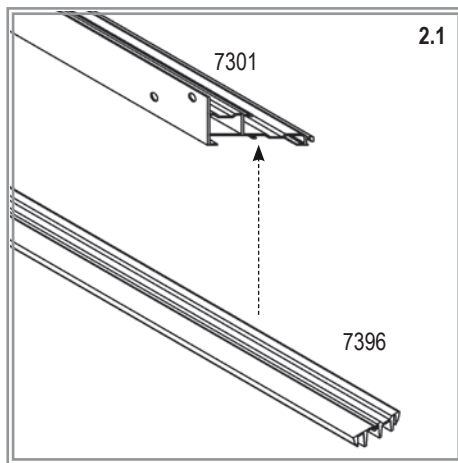
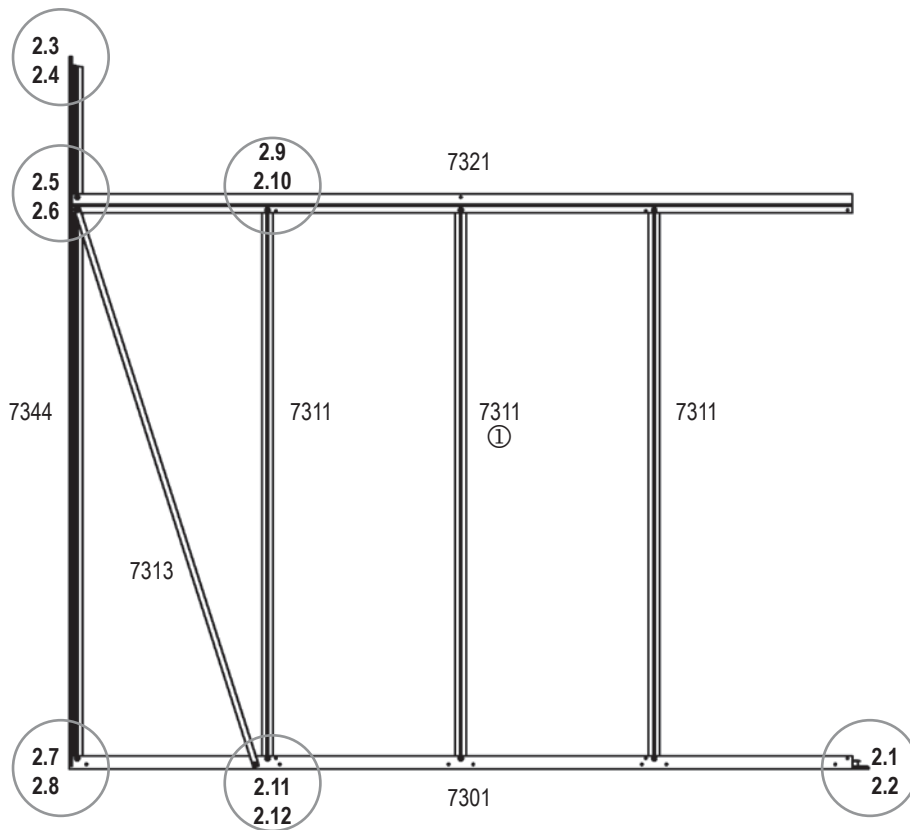

HELENA



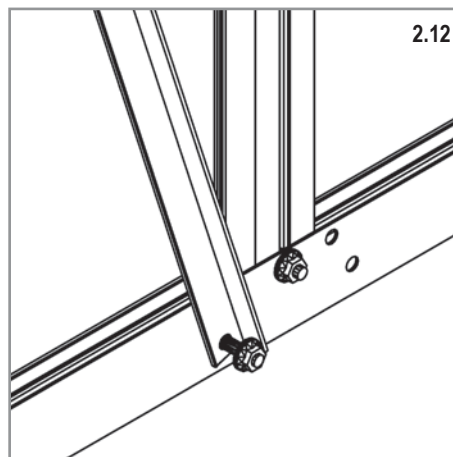
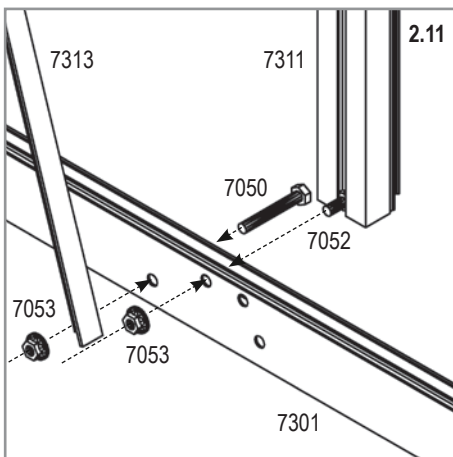
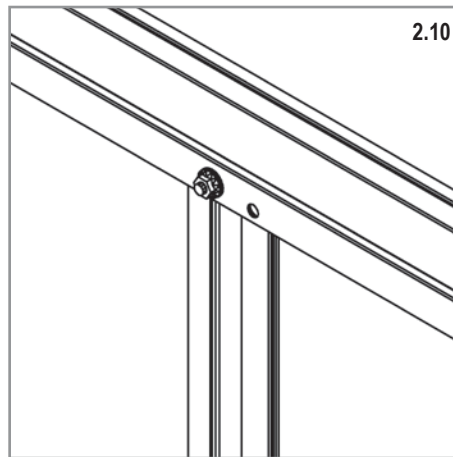
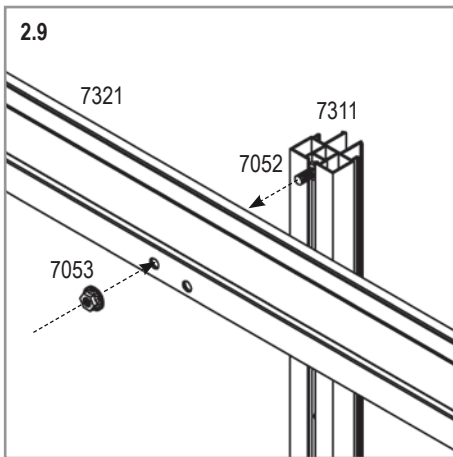
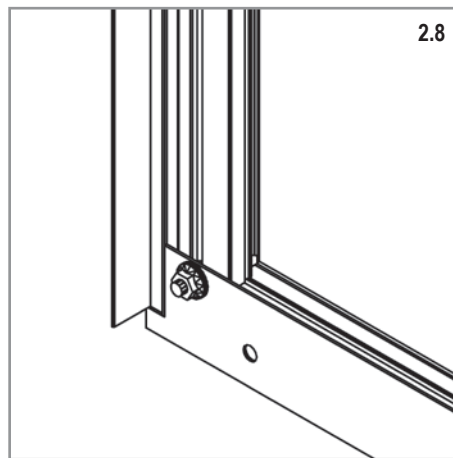
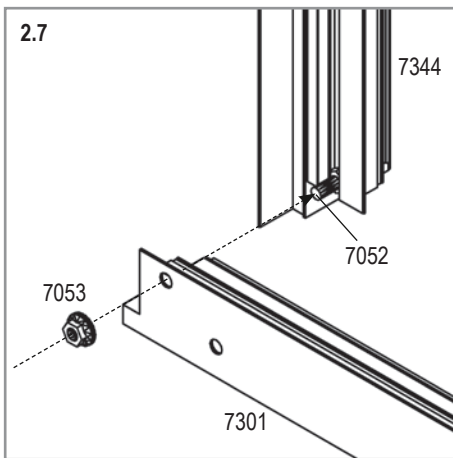
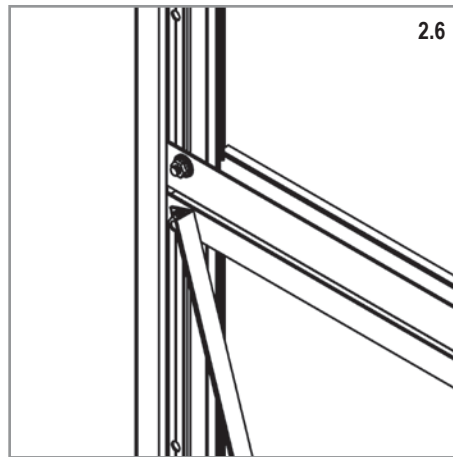
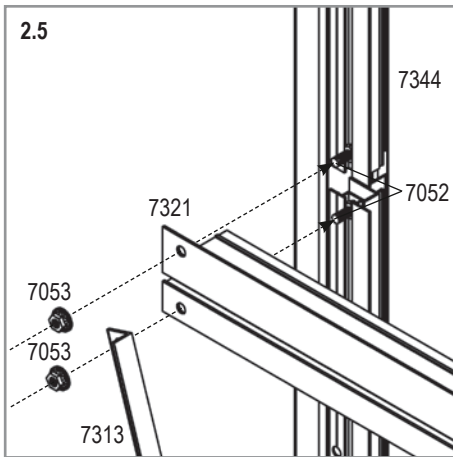





2



HELENA

3



7000	8600	10200	11900
7050 			
1	1	1	1
7052 			
7	7	7	7
7053 			
8	8	8	8
7302 			
1	1	1	1
7311 			
2	2	2	2
7313 			
1	1	1	1
7322 			
1	1	1	1
7345 			
1	1	1	1
7396 			
2	2	2	2

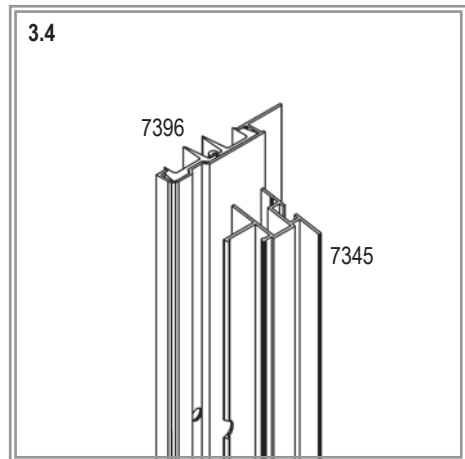
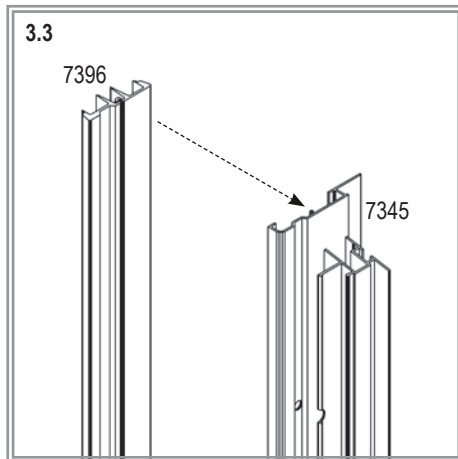
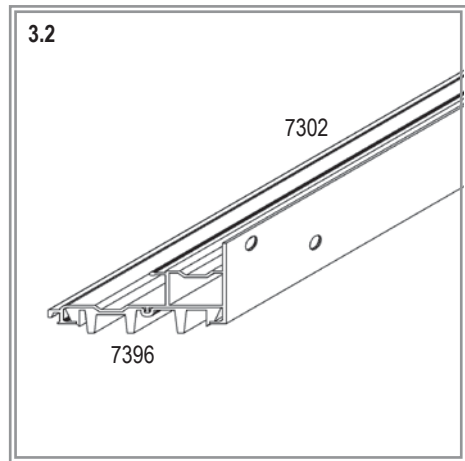
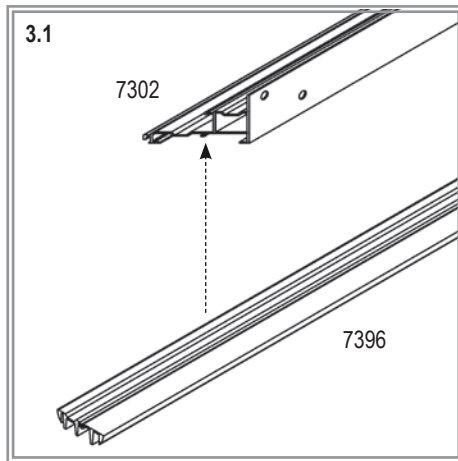
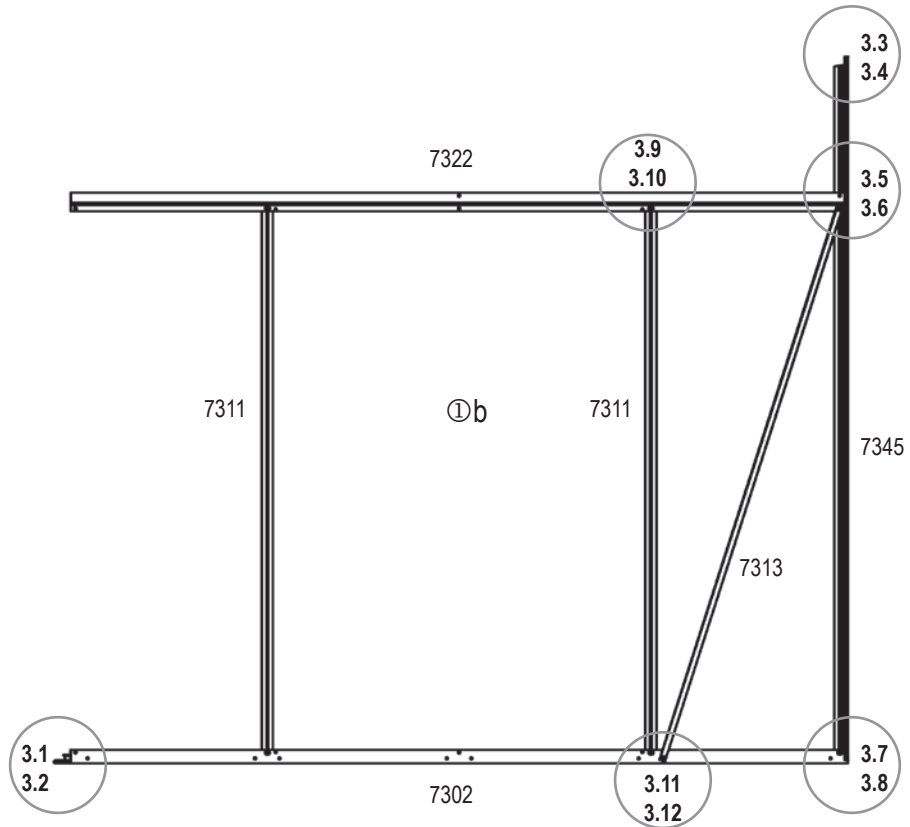

HELENA

3

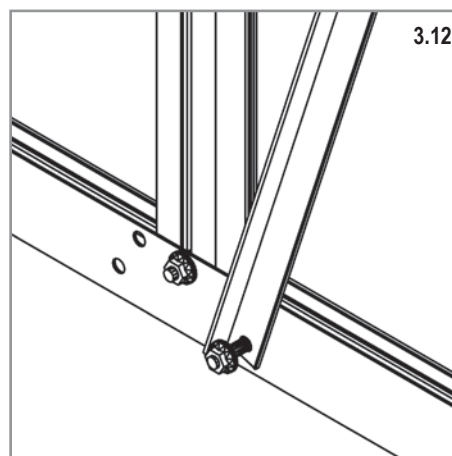
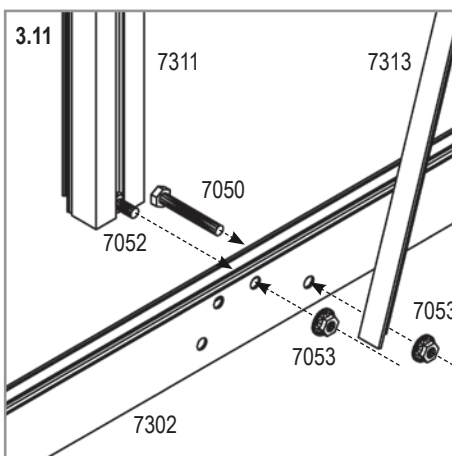
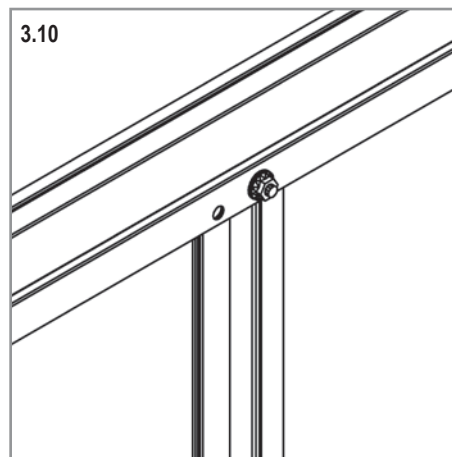
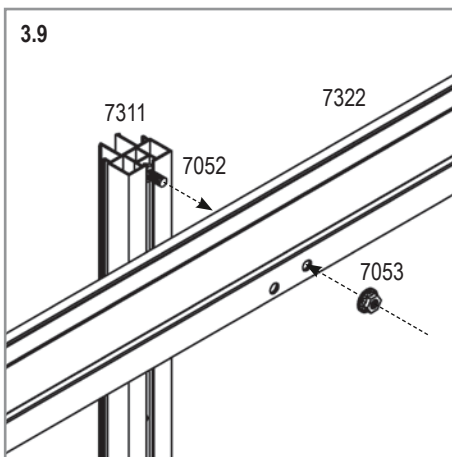
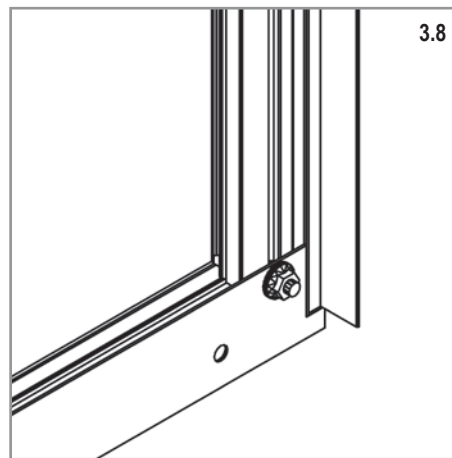
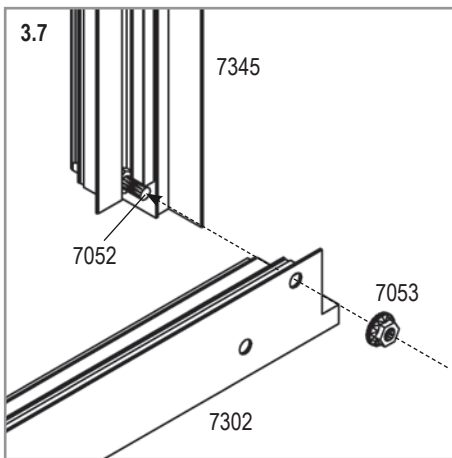
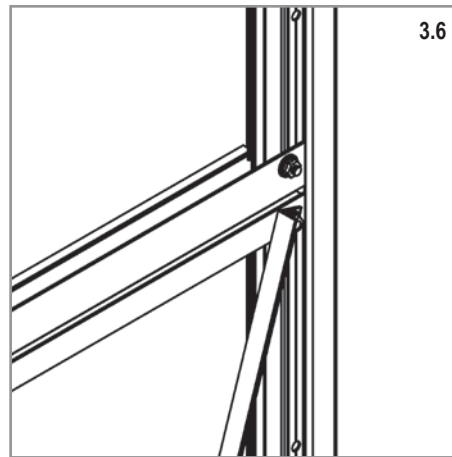
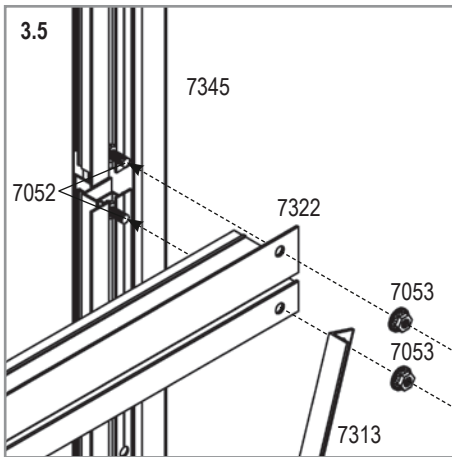

HELENA

4a



7000	8600	10200	11900
7052			
22	22	22	22
7053			
22	22	22	22
7334	7335	7336	7337
1	1	1	1
7340			
1	1	1	1
7341			
1	1	1	1
7346			
1	1	1	1
7347			
1	1	1	1
7348			
4	4	4	4
7395			
2	2	2	2
7396			
1	1	1	1
7411			
12	13	14	15
7412			
10	10	10	10
7414	7415	7416	7417
1	1	1	1
7421			
12	13	14	15
7422			
10	10	10	10

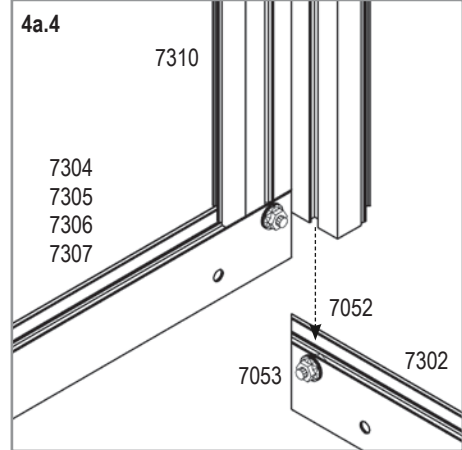
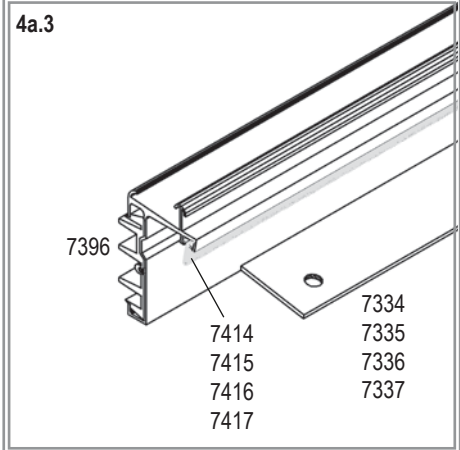
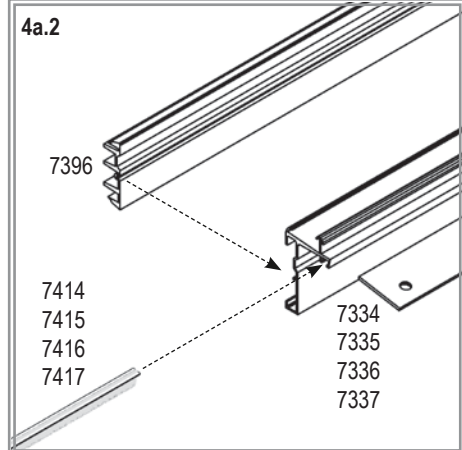
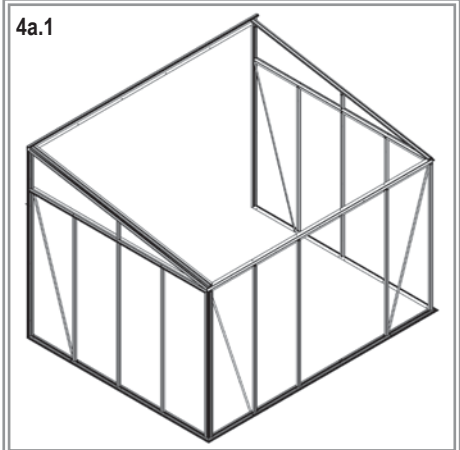
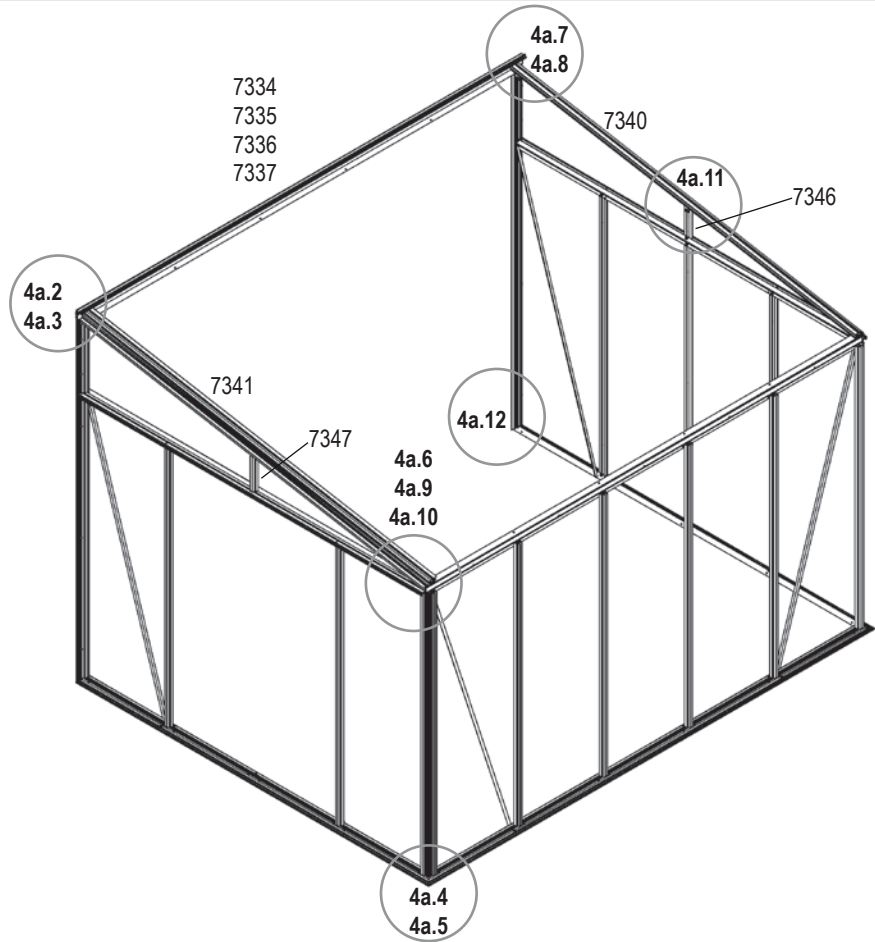

HELENA

4a

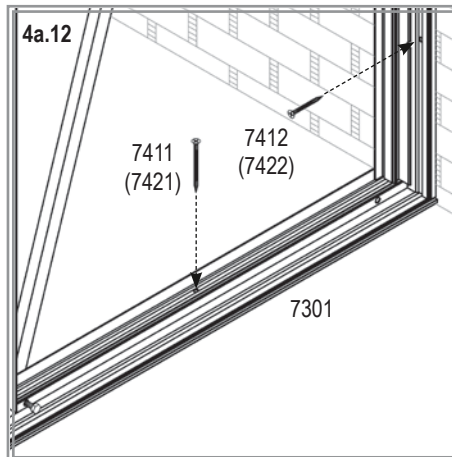
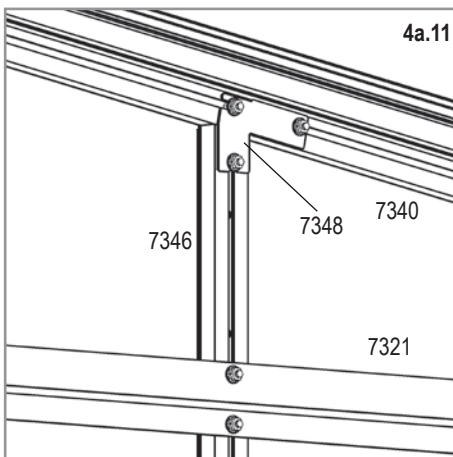
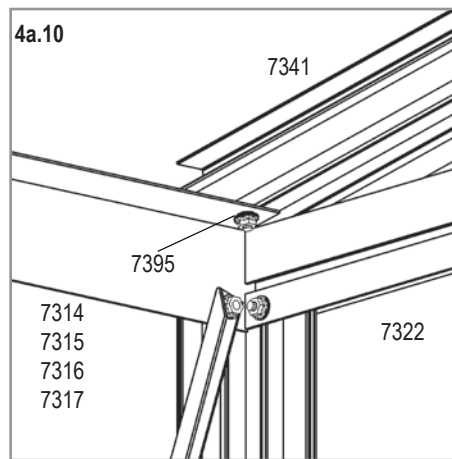
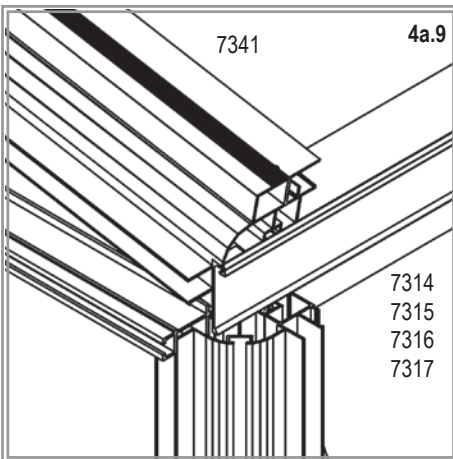
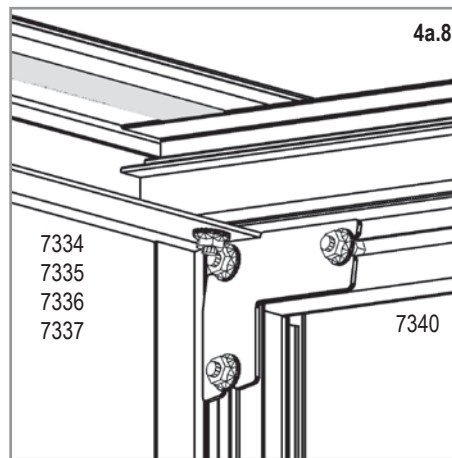
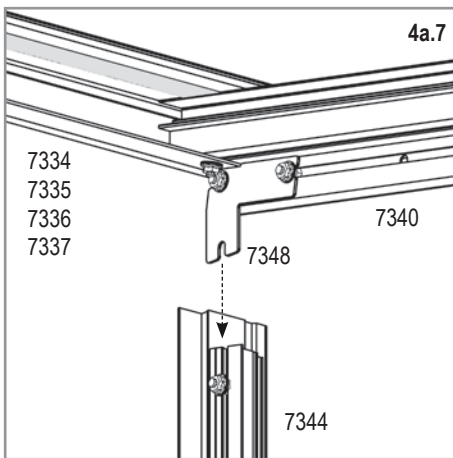
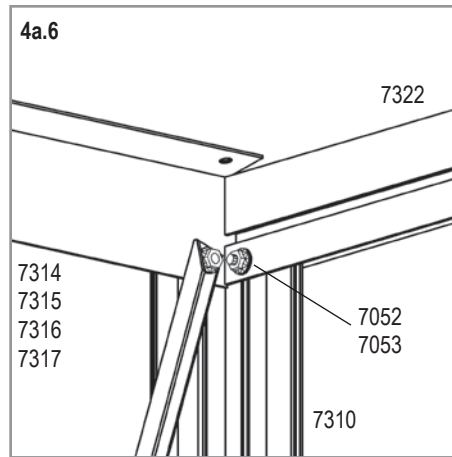
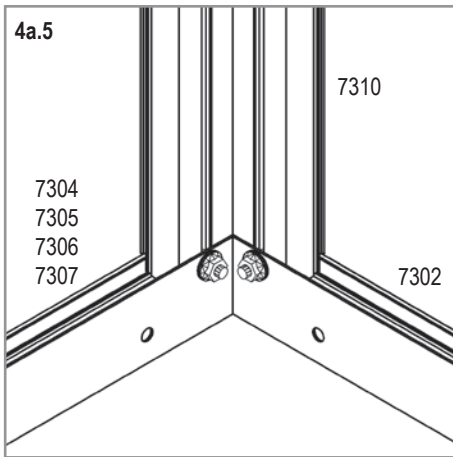

HELENA

4b



7000	8600	10200	11900
1006			
4	8	8	12
6056			
2	4	4	6
7048			
2	4	4	6
7052			
6	8	10	12
7053			
18	24	30	36
7055			
2	4	4	6
7330			
3	4	5	6
7331			
3	4	5	6
7368			
1	2	2	3
7395			
3	4	5	6
7399			
12	16	20	24
7412			
4	5	6	7
7422			
4	5	6	7

HELENA

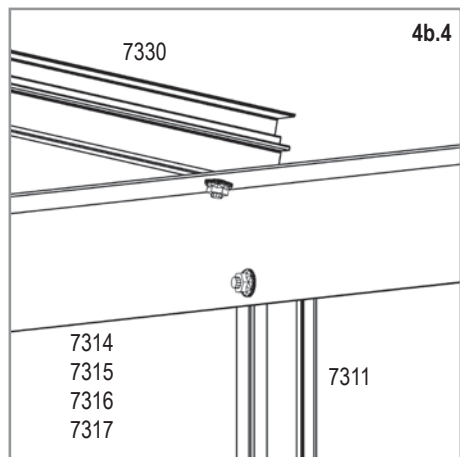
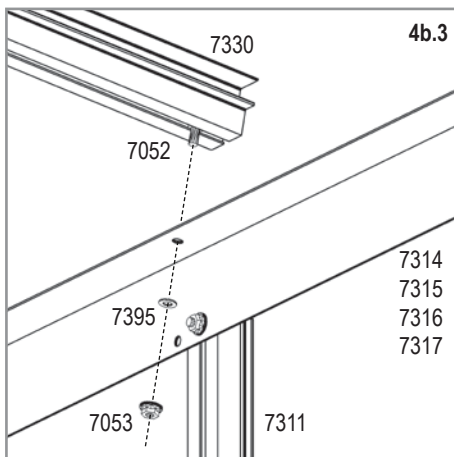
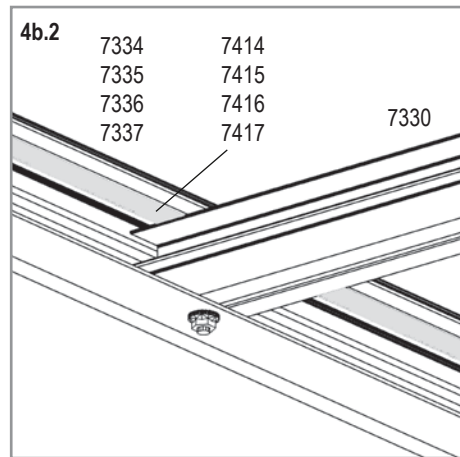
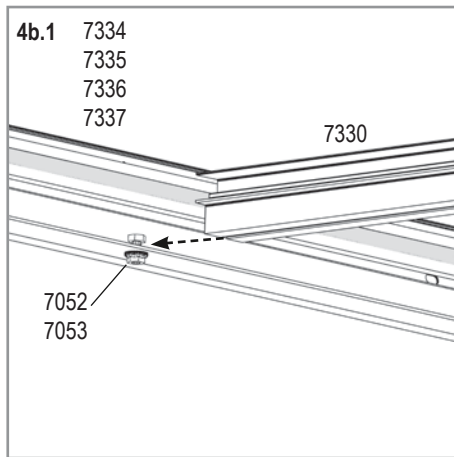
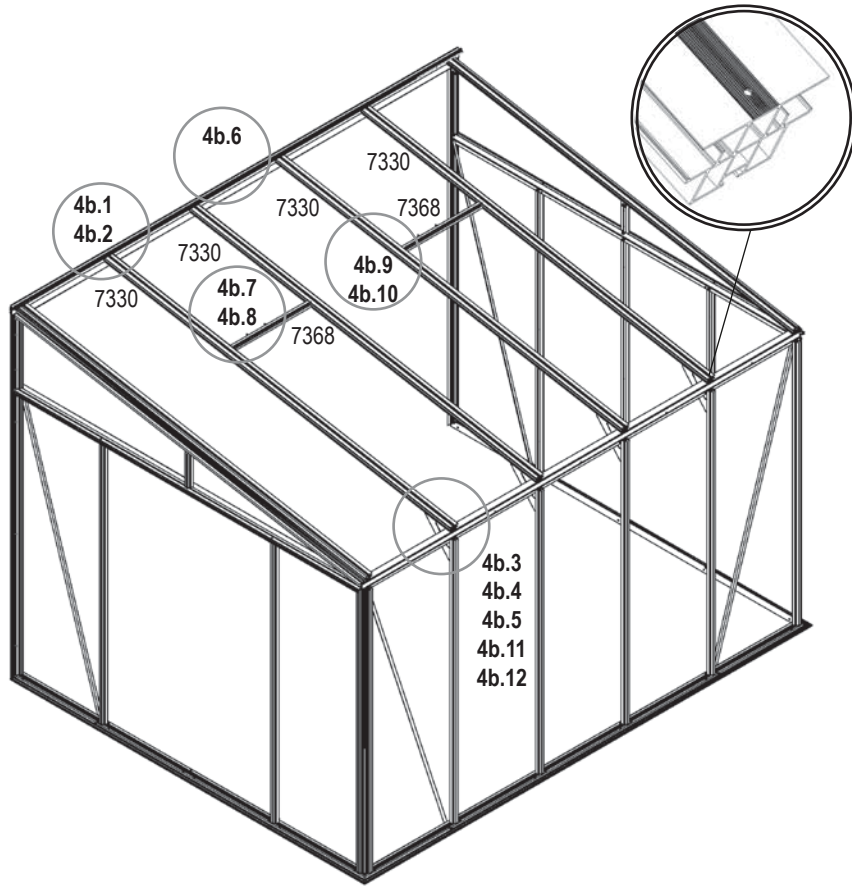

4b

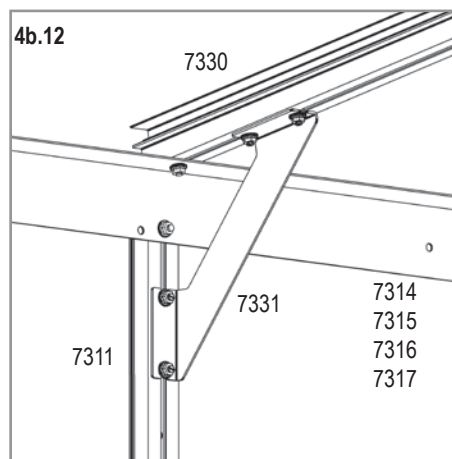
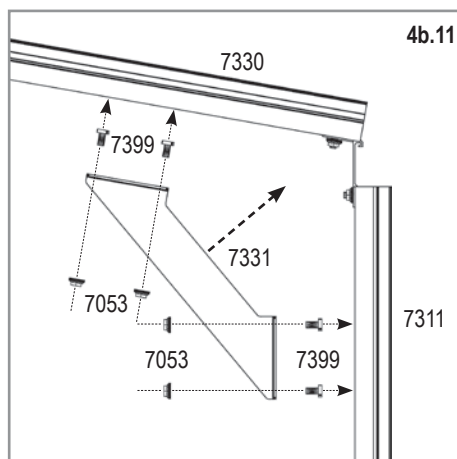
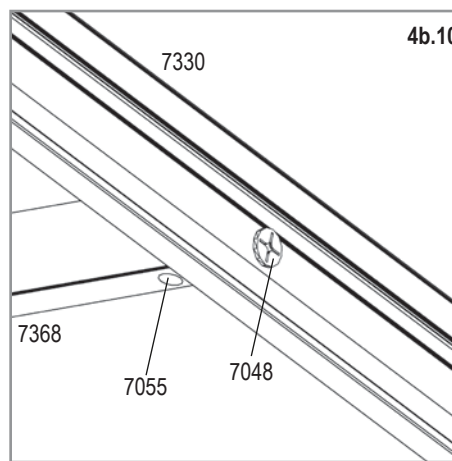
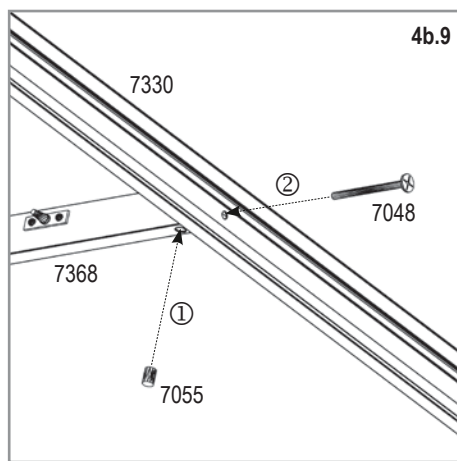
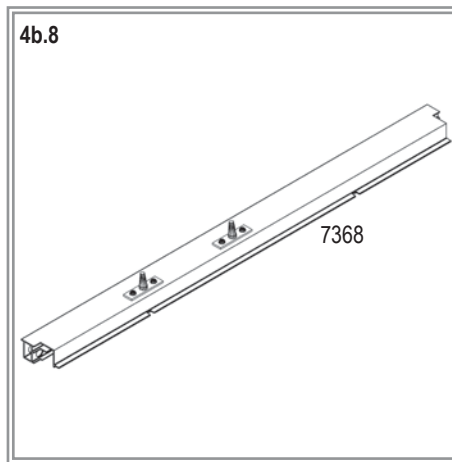
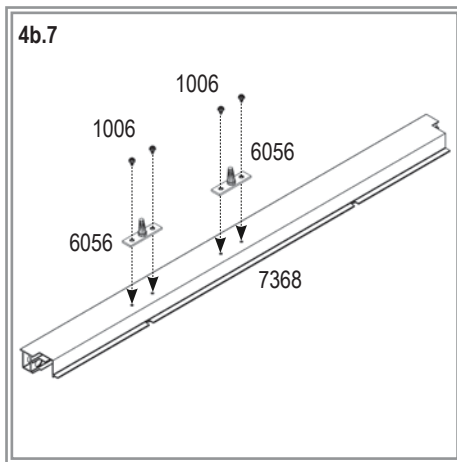
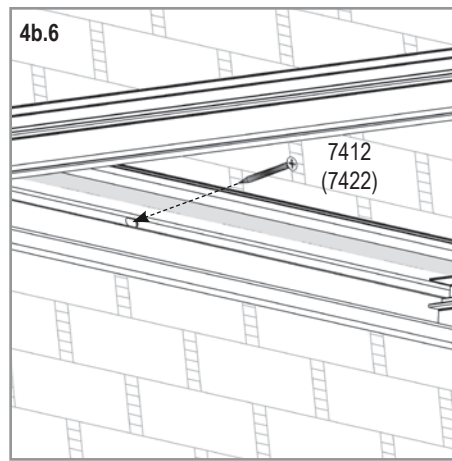
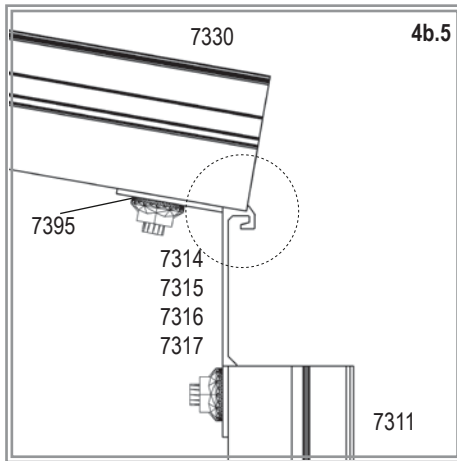

HELENA

5



7000	8600	10200	11900
1x	2x	2x	3x
1006			
1x2	2x2	2x2	3x2
6070			
1x4	2x4	2x4	3x4
7052			
1x4	2x4	2x4	3x4
7053			
1x4	2x4	2x4	3x4
7090			
1x1	2x1	2x1	3x1
7365			
1x1	2x1	2x1	3x1
7366			
1x1	2x1	2x1	3x1
7367 (7391)			
1x2	2x2	2x2	3x2

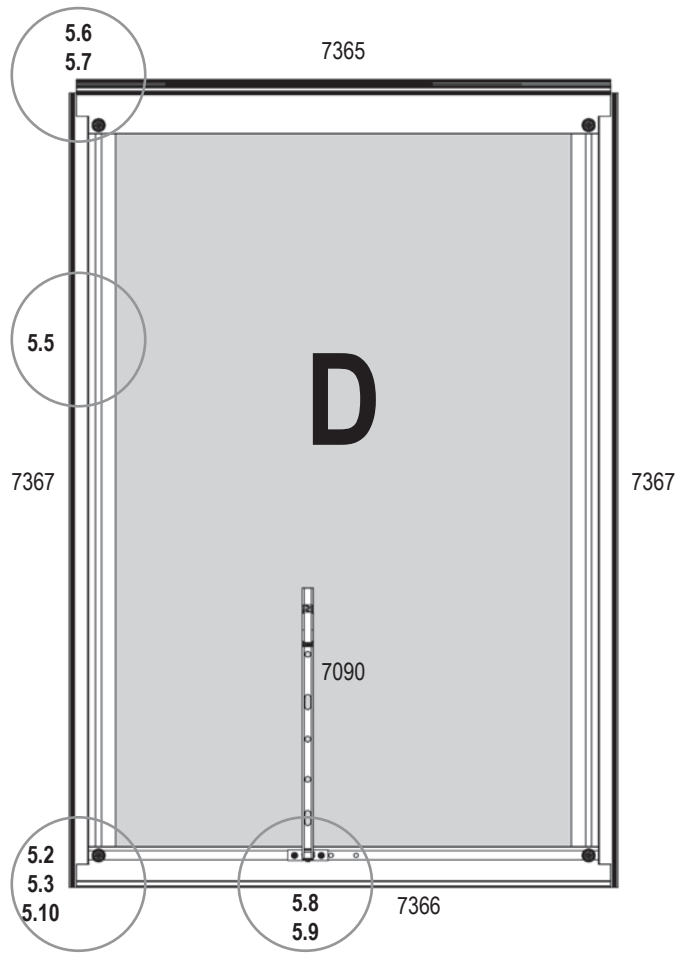

5.1	POLYCARBONATE				QUANTITY / MODEL			
	10 MM		16 MM		7000	8600	10200	11900
	ART. No.	MM	ART. No.	MM				
D	369581	555 x 870	369591	530 x 853	1x1	2x1	2x1	3x1

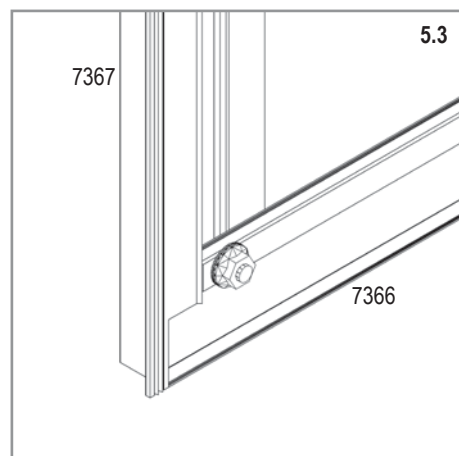
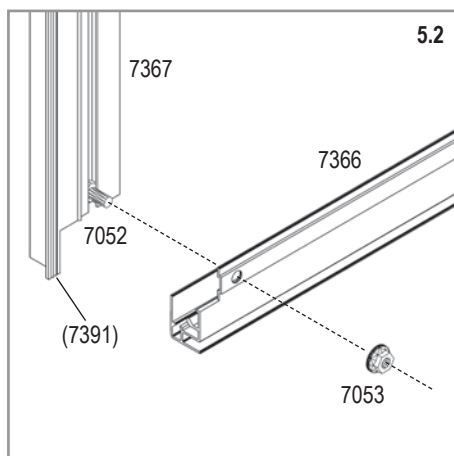





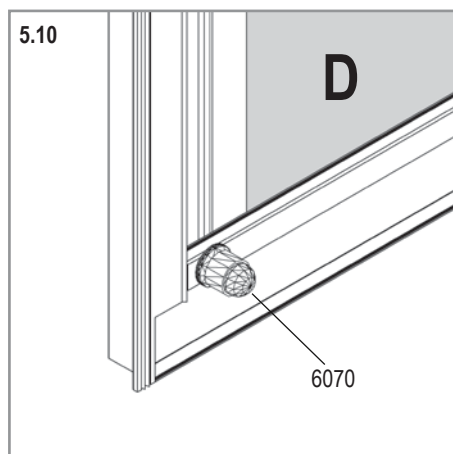
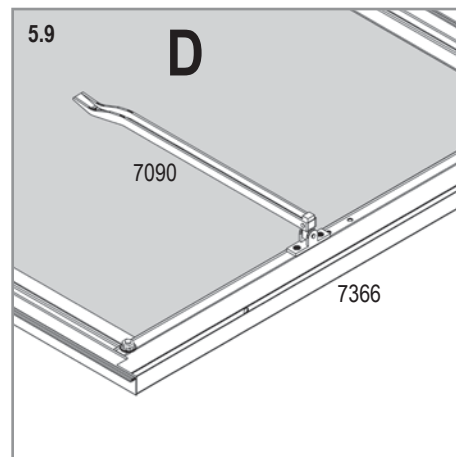
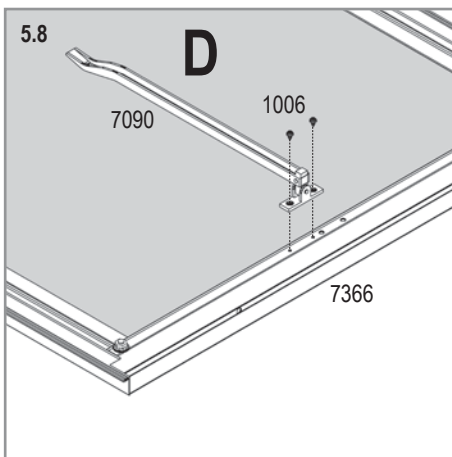
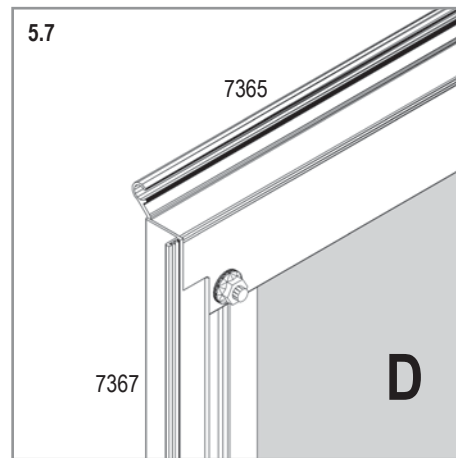
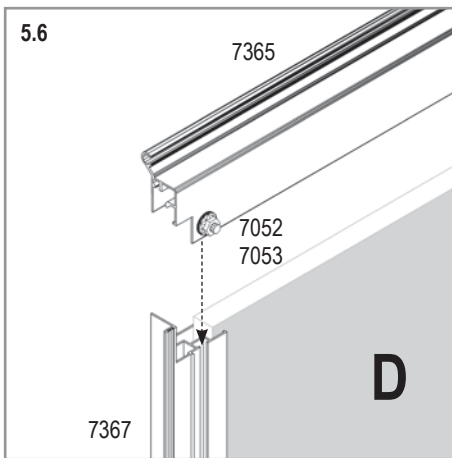
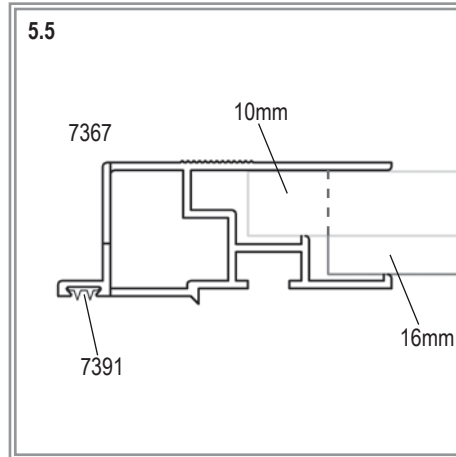
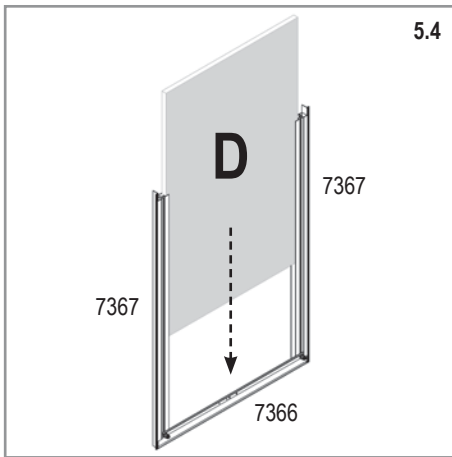

















HELENA

5





6a

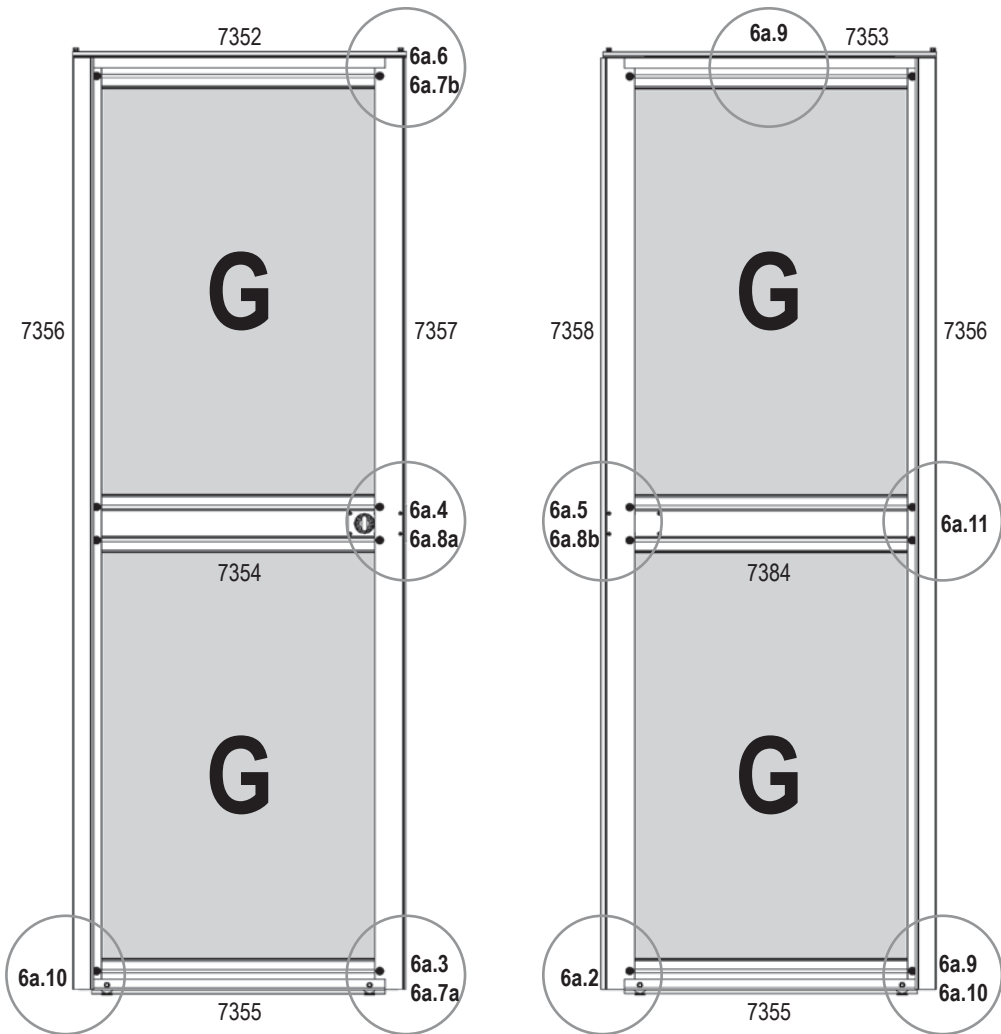

- All Models**
- 2271 x4 
 - 7052 x16 
 - 7053 x16 
 - 7290 x1 
 - 7332 x1 
 - 7350 x4 
 - 7352 x1 
 - 7353 x1 
 - 7354 x1 
 - 7355 x2 
 - 7356 x2 
 - 7357 x1 
 - 7358 x1 
 - 7360 x4 
 - 7364 x4 
 - 7384 x1 
 - 7392 x8 
 - 7393 x4 
 - 7400 x1 
 - 7401 x1 
 - 7402 x1 
 - 7404 x8 
 - 7405 x4 

HELENA



6a.1	GLASS		POLYCARBONATE				QUANTITY / MODEL			
	4 MM		10 MM		16 MM		7000	8600	10200	11900
	ART. No.	MM	ART. No.	MM	ART. No.	MM				
G 	367853	619 x 843	369586	619 x 843	369596	595 x 823	4	4	4	4

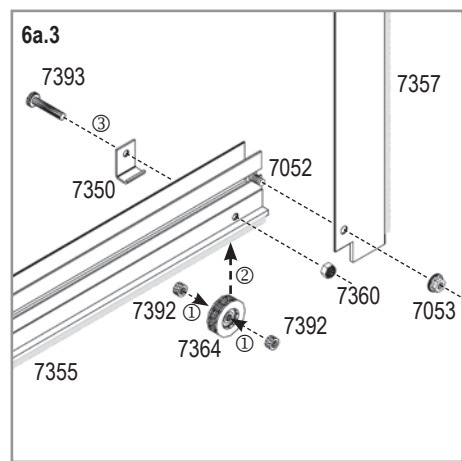
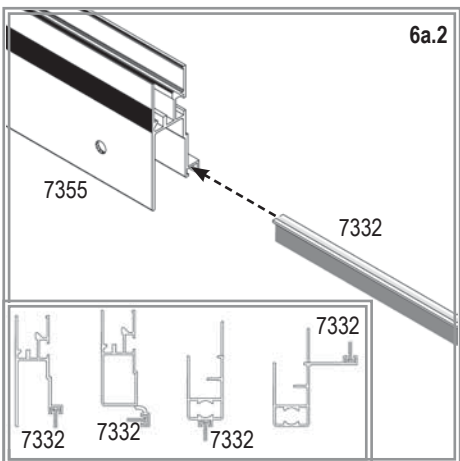

6a

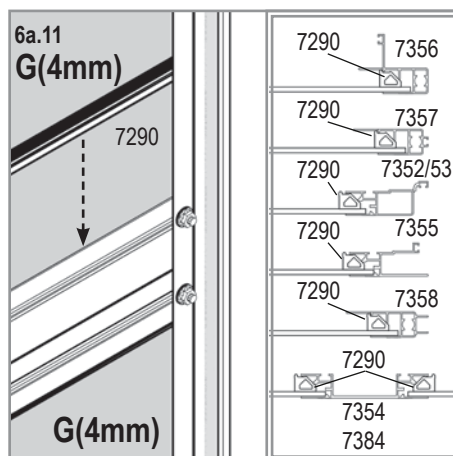
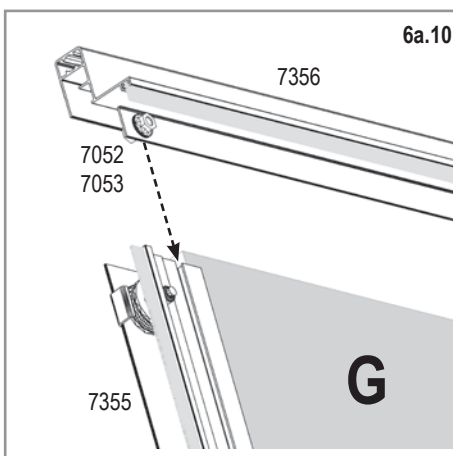
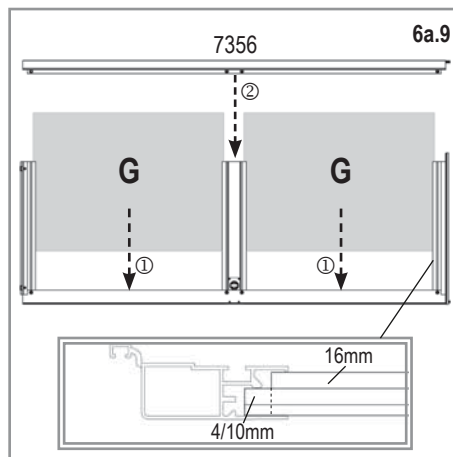
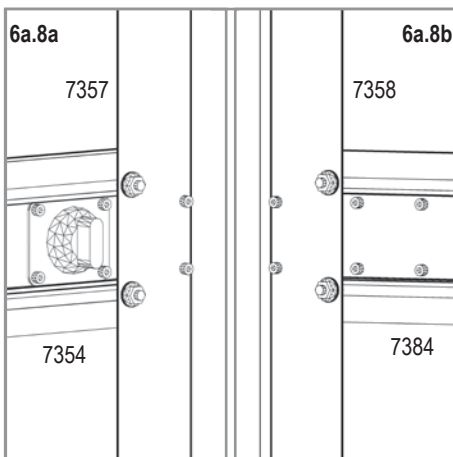
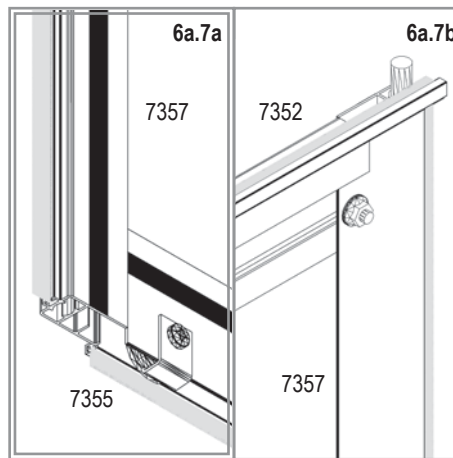
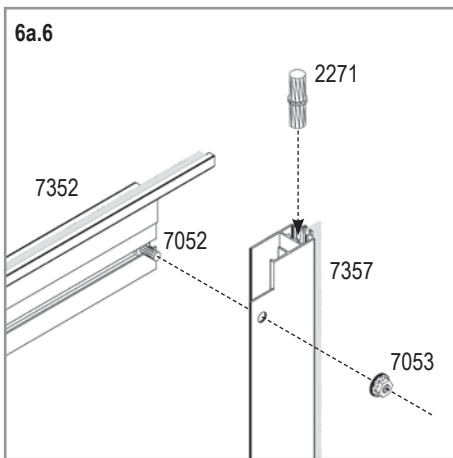
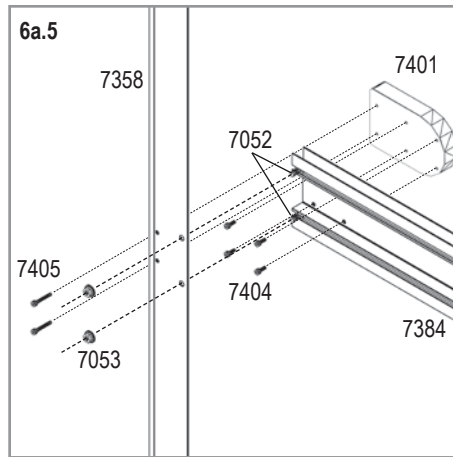
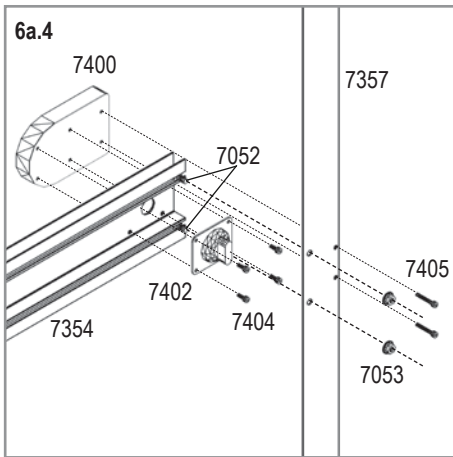

HELENA

6b



All Models

2002 x2	
2003 x2	
7052 x4	
7053 x8	
7351 x1	
7361 x2	
7362 x1	
7363 x1	
7390 x4	

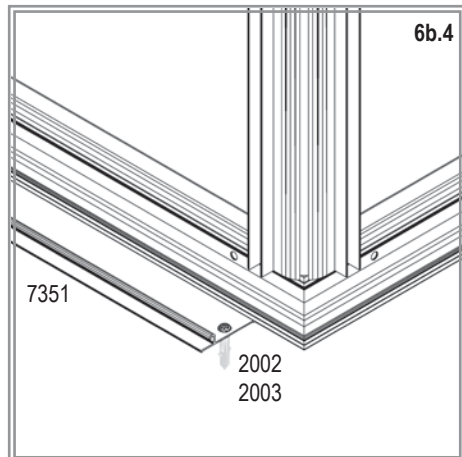
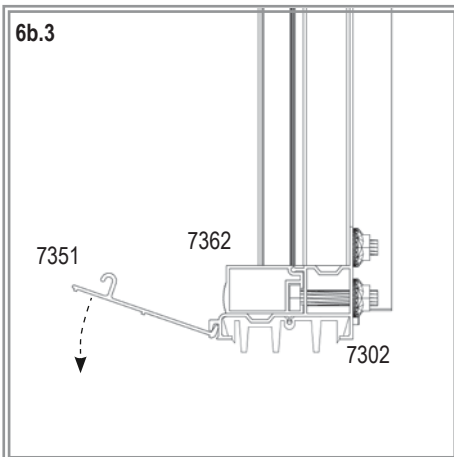
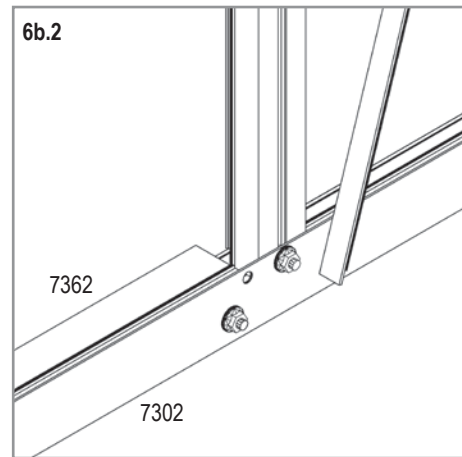
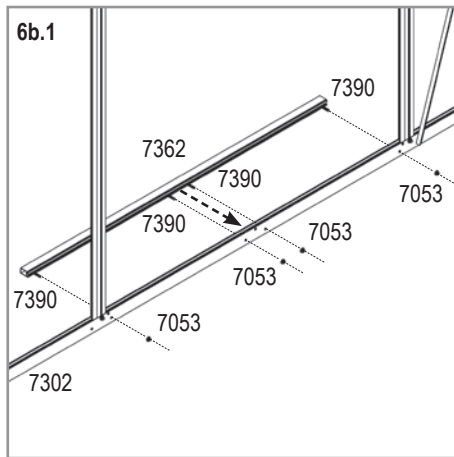
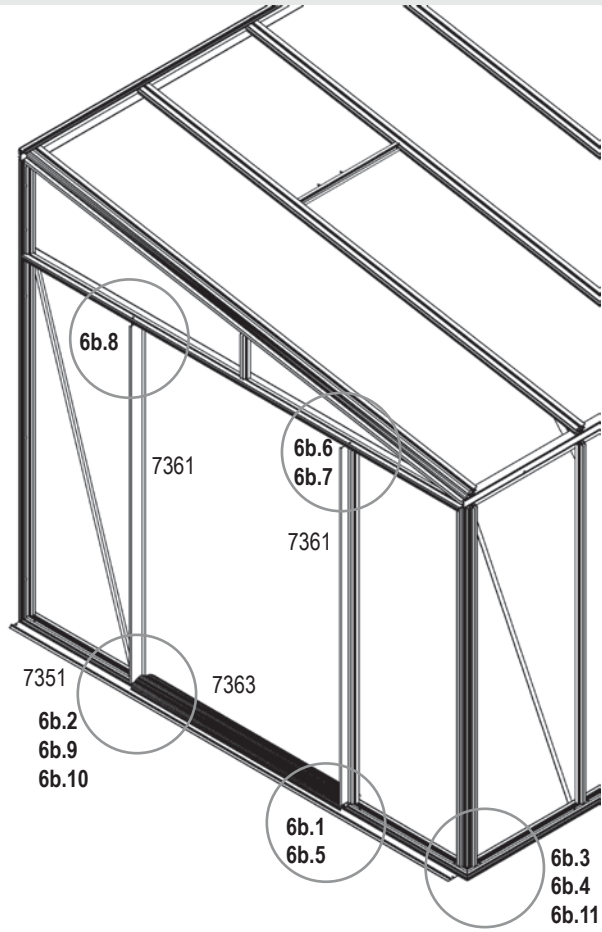

HELENA

6b

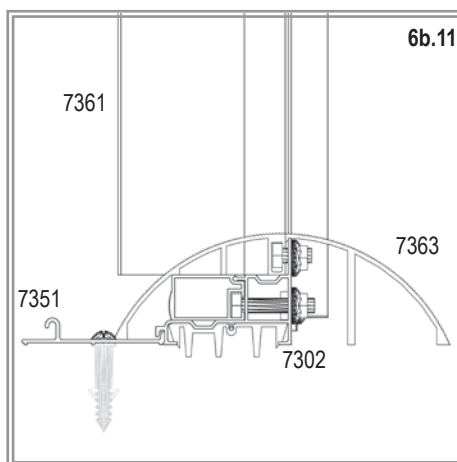
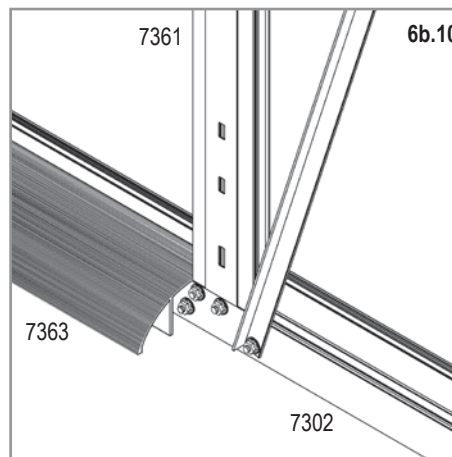
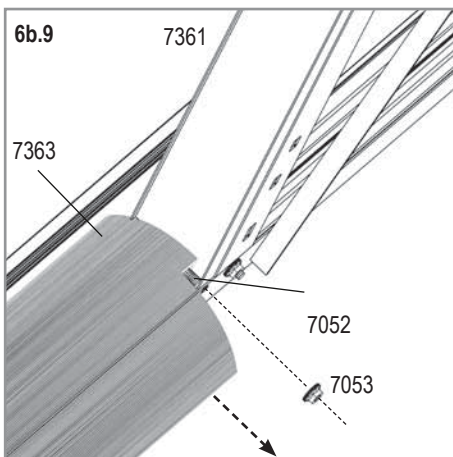
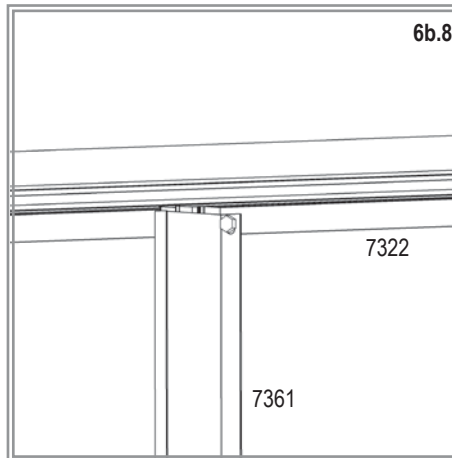
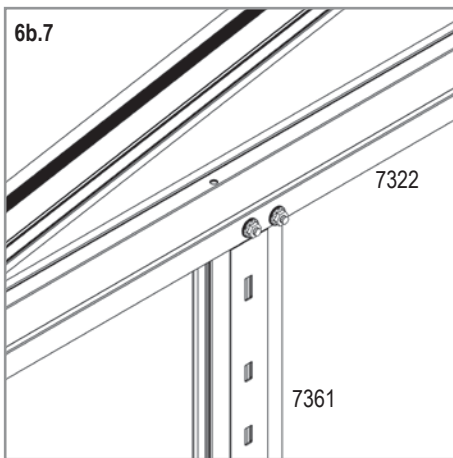
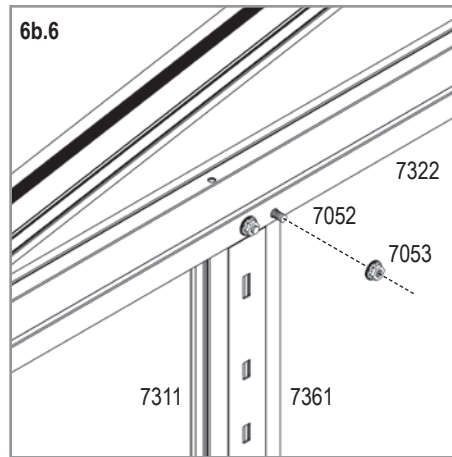
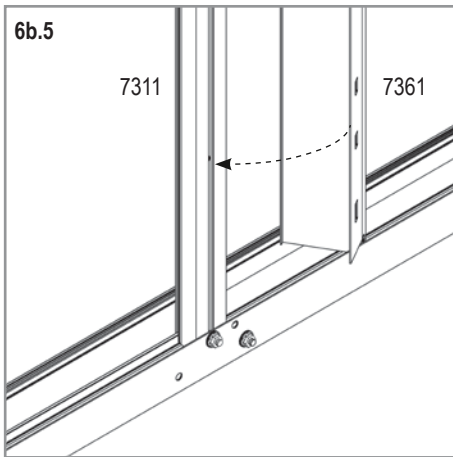

HELENA

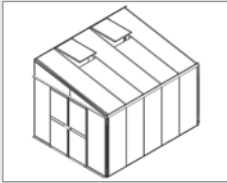

7.1	GLASS		POLYCARBONATE				QUANTITY / MODEL			
	4 MM		10 MM		16 MM		7000	8600	10200	11900
	ART. No.	MM	ART. No.	MM	ART. No.	MM				
A	367850	610 x 1816	369580	610 x 1816	369590	610 x 1816	10	11	12	13
B	-	-	369584	610 x 2577	369594	595 x 2577	3	3	4	4
C	-	-	369585	610 x 1693	369595	595 x 1685	1	2	2	3
D	-	-	369581	555 x 870	369591	530 x 853	1	2	2	3
EL	367851	1239 x 230/11.5	369582	1239 x 230/11.5	369592	1239 x 230/11.5	1	1	1	1
ER			369587		369597		1	1	1	1
FL	367852	1239 x 452/233.5	369583	1239 x 452/233.5	369593	1239 x 452/233.5	1	1	1	1
FR			369588		369598		1	1	1	1
G	367853	619 x 843	369586	619 x 843	369596	595 x 823	4	4	4	4
TOTAL							23	26	28	31

Back Gabel - all models

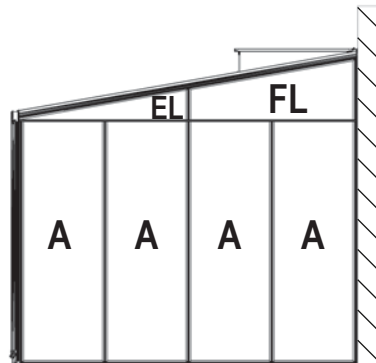

(7000)

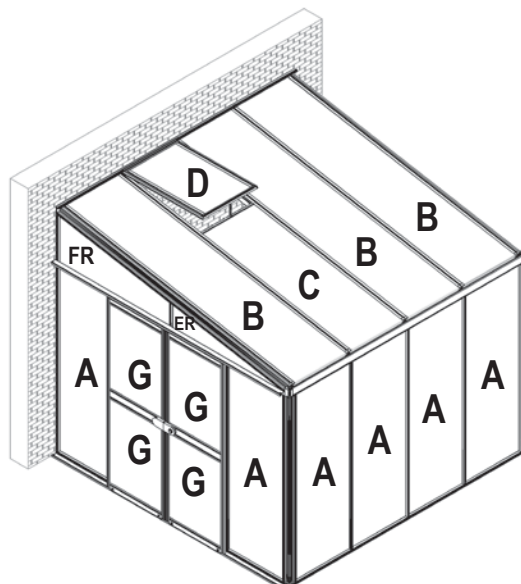

HELENA

7

(8600)

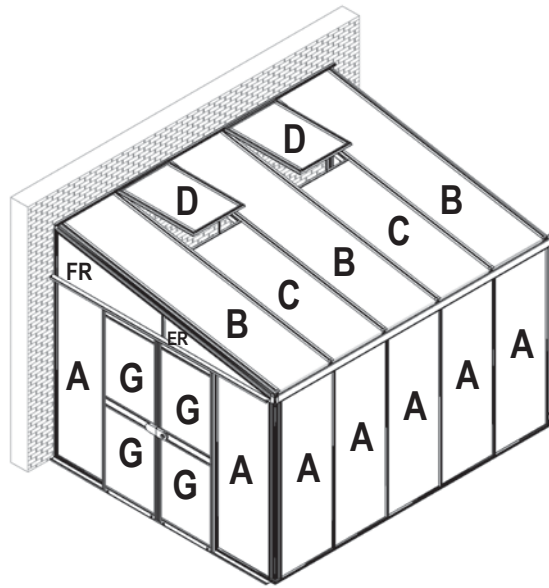

(10200)

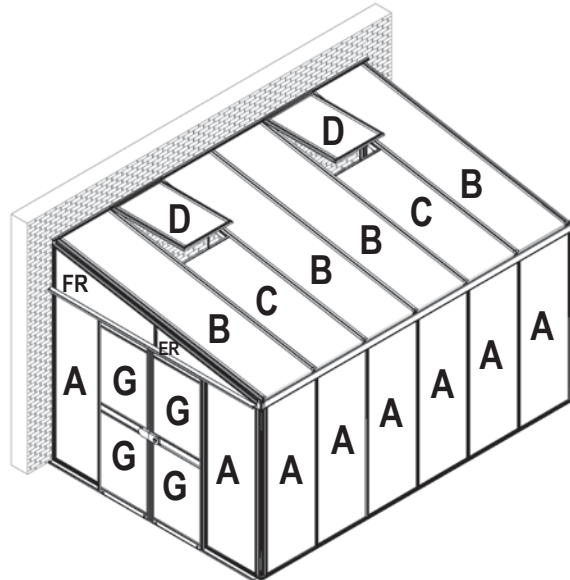

(11900)

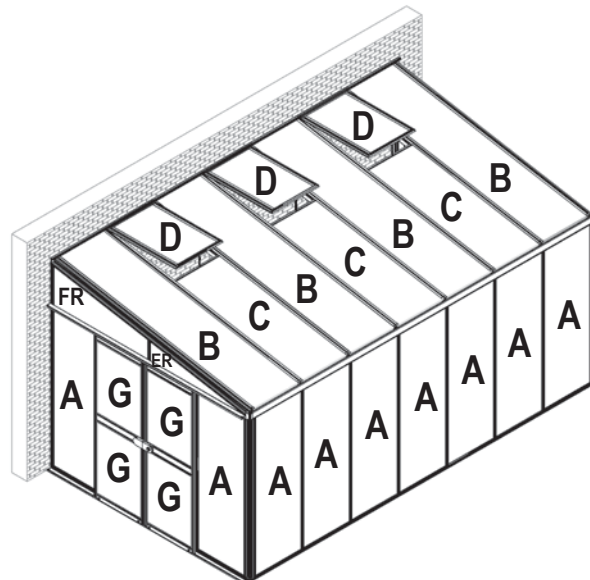

HELENA

7a



7000	8600	10200	11900
7052			
4	5	6	7
7053			
4	5	6	7
7323			
4	5	6	7
7324	7325	7326	7327
1	1	1	1
7333			
4	5	6	7
7342			
2	2	2	2
7343			
3	4	5	6
7349			
13	16	19	22

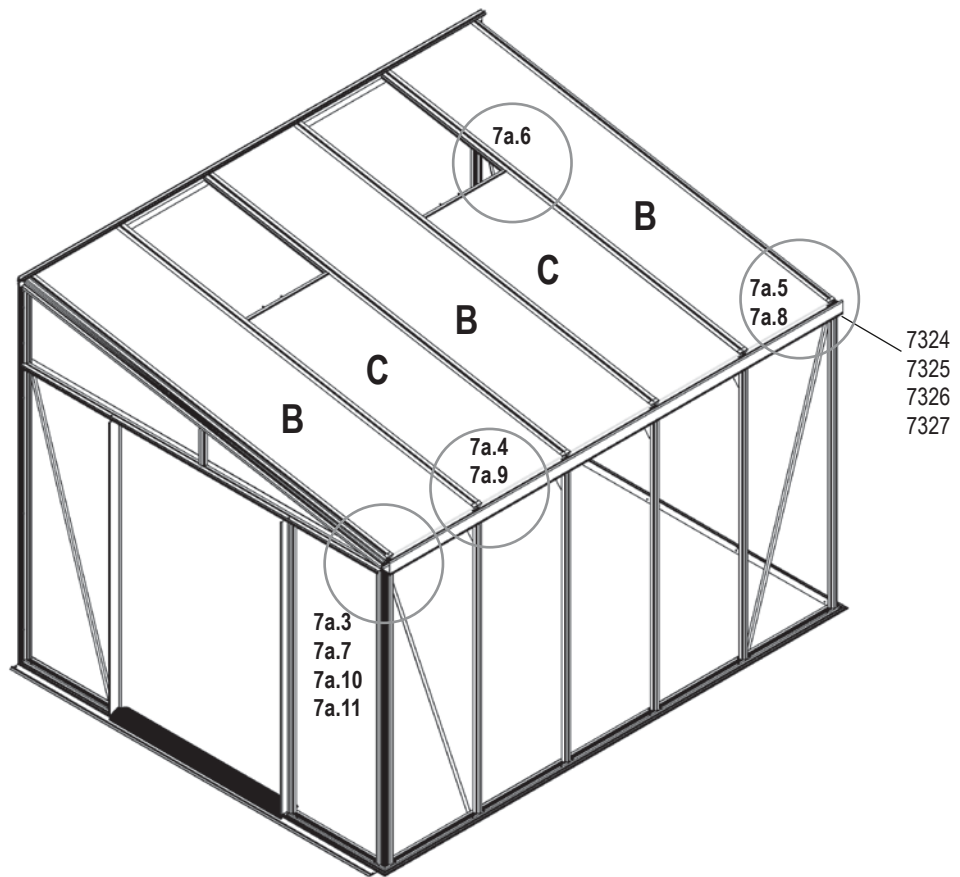

7a.1	POLYCARBONATE				QUANTITY / MODEL			
	10 MM		16 MM		7000	8600	10200	11900
	ART. No.	MM	ART. No.	MM				
B	369584	610 x 2577	369594	595 x 2577	3	3	4	4
C	369585	610 x 1693	369595	595 x 1685	1	2	2	3

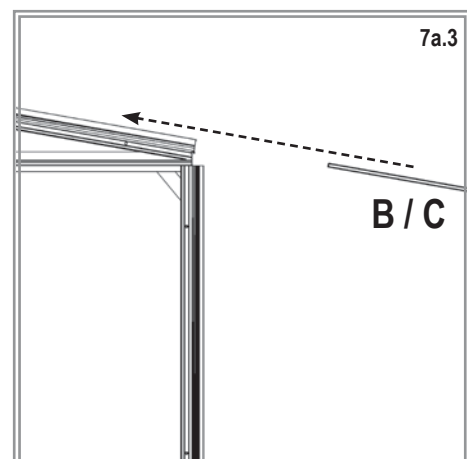
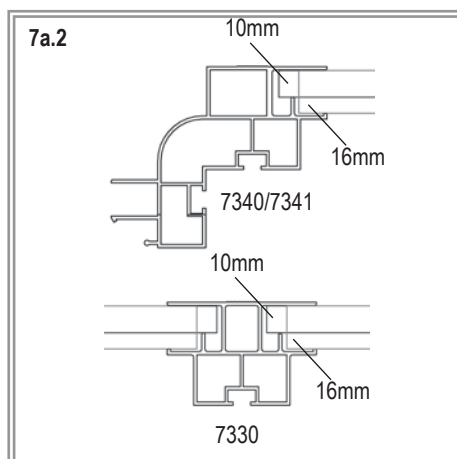

HELENA

7a

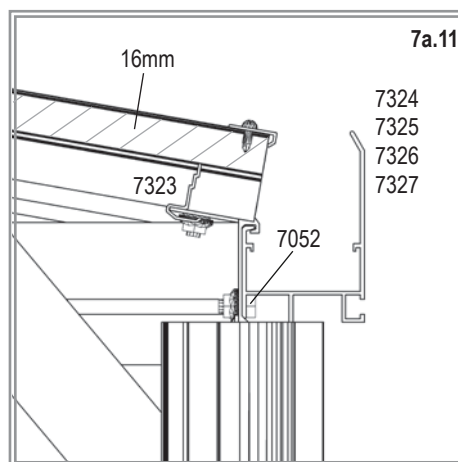
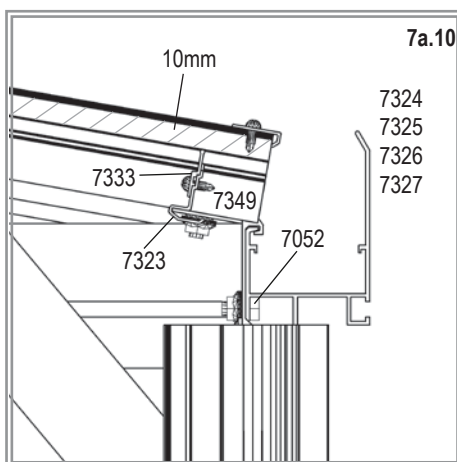
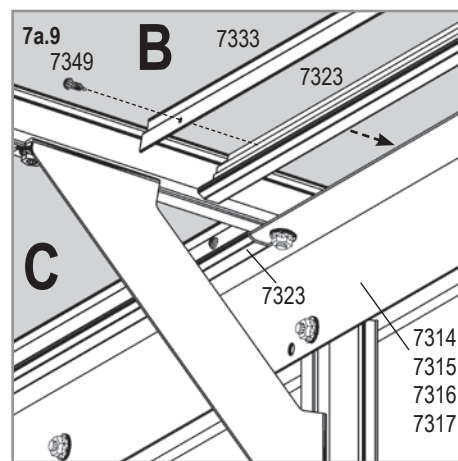
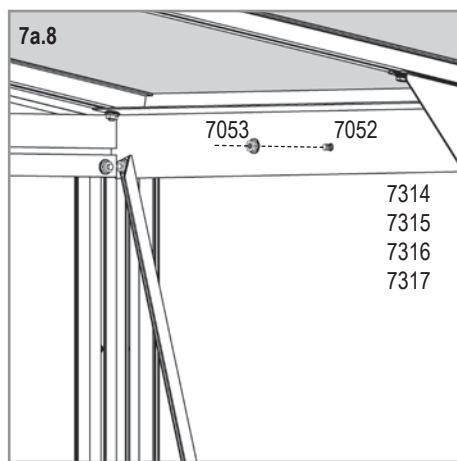
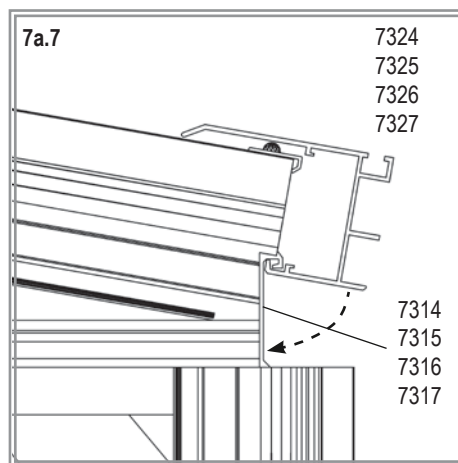
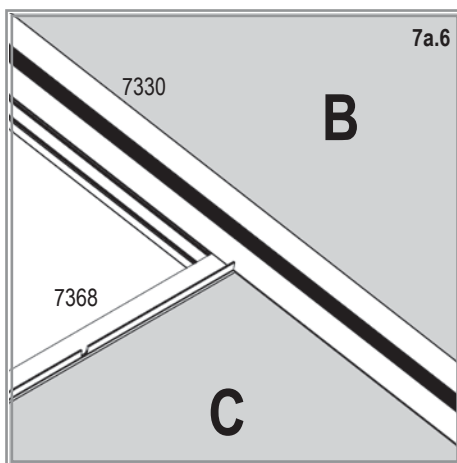
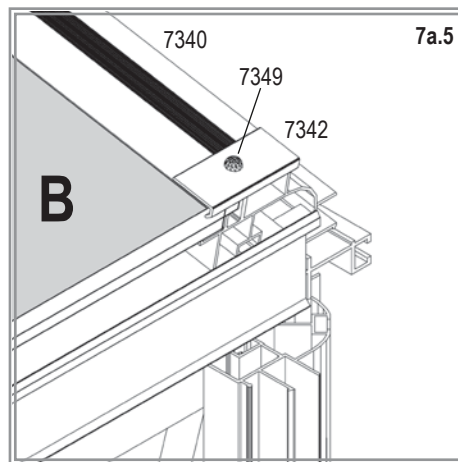
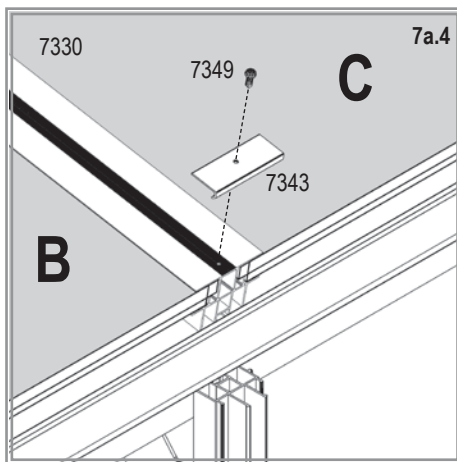

HELENA

7b

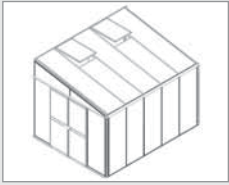

7000	8600	10200	11900
7050			
78	83	88	93
7053			
78	83	88	93
7372			
8	9	10	11
7381			
10	11	12	13
7407			
10	11	12	13
All Models			
6090			
x1			
7373			
x4			
7374			
x2			
7375			
x1			
7376			
x1			
7377			
x1			
7378			
x1			
7379			
x1			
7380			
x1			
7409			
x8			

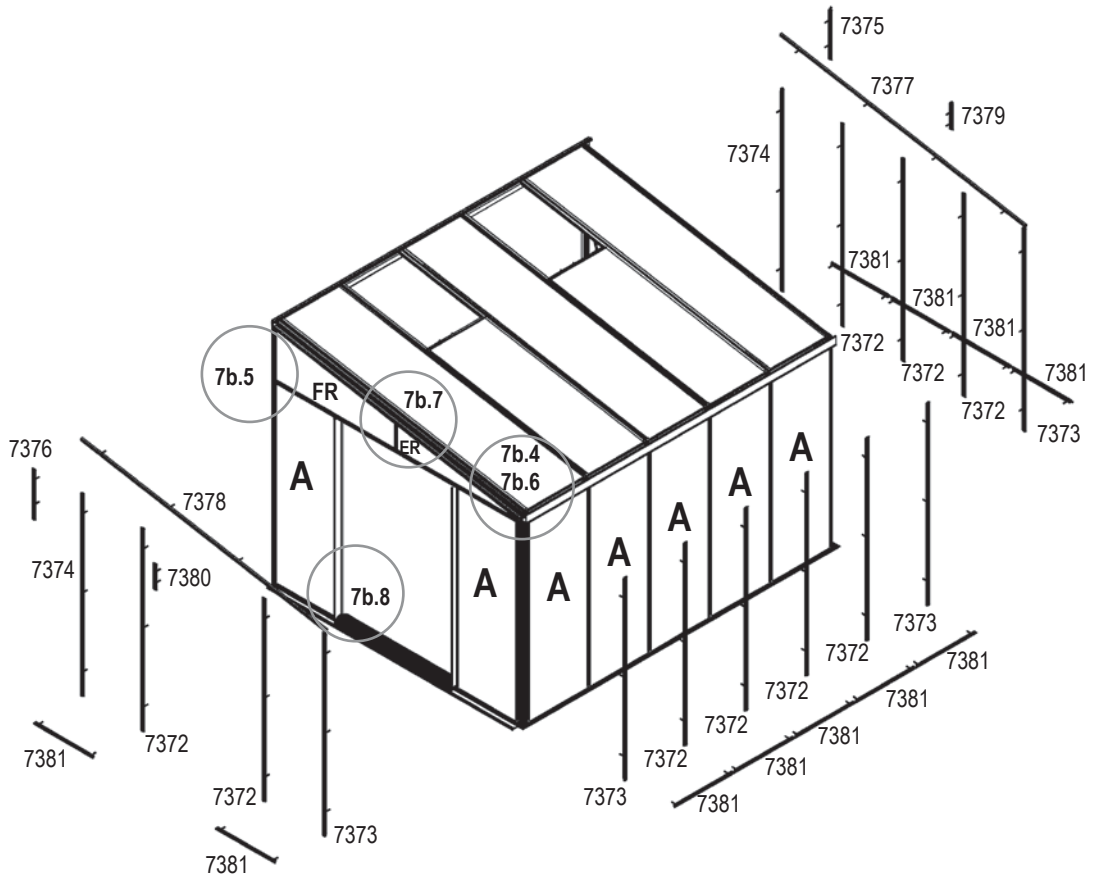

7b.1	GLASS		POLYCARBONATE				QUANTITY / MODEL			
	4 MM		10 MM		16 MM		7000	8600	10200	11900
	ART. No.	MM	ART. No.	MM	ART. No.	MM				
A	367850	610 x 1816	369580	610 x 1816	369590	610 x 1816	10	11	12	13
EL	367851	1239 x 230/11.5	369582	1239 x 230/11.5	369592	1239 x 230/11.5	1	1	1	1
ER			369587		369597		1	1	1	1
FL	367852	1239 x 452/233.5	369583	1239 x 452/233.5	369593	1239 x 452/233.5	1	1	1	1
FR			369588		369598		1	1	1	1

HELENA

7b

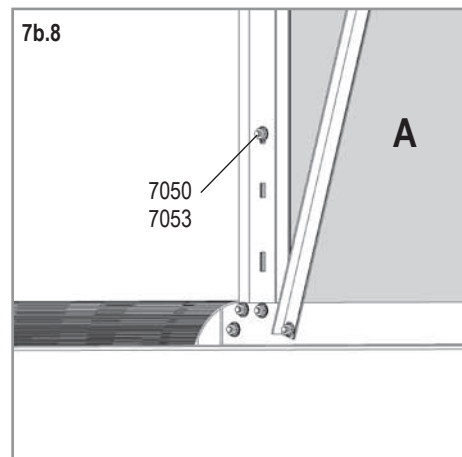
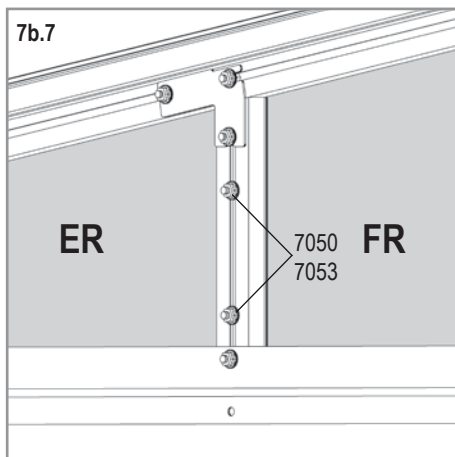
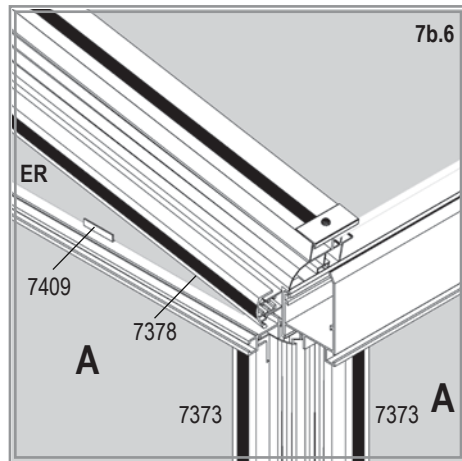
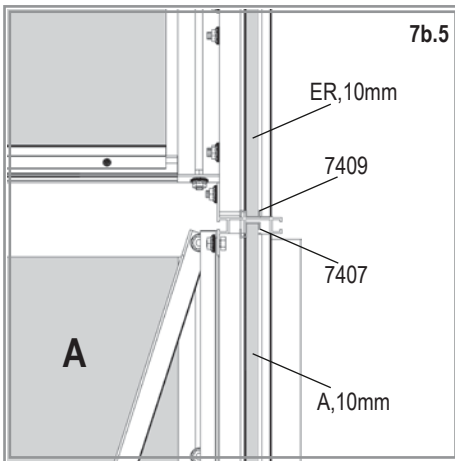
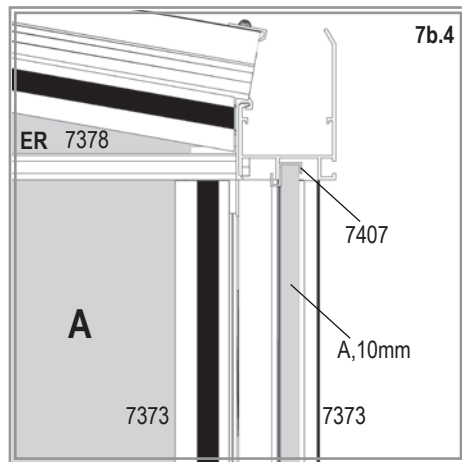
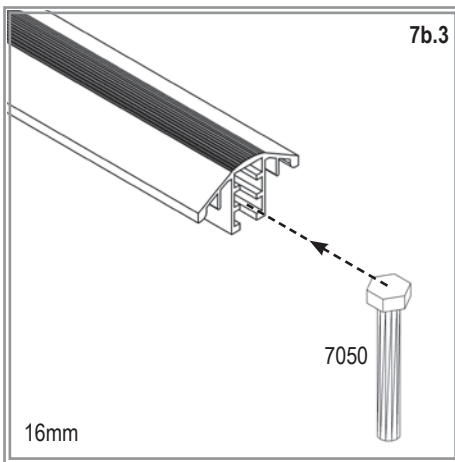
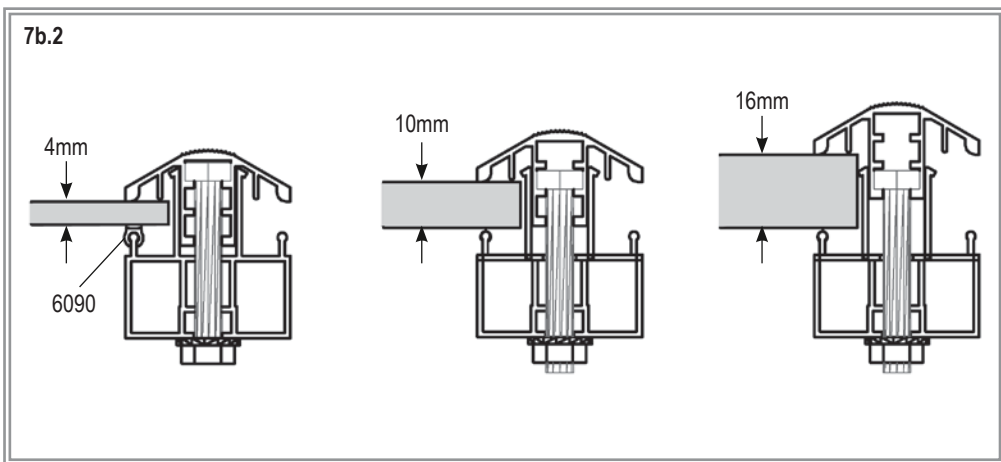

HELENA

8



7000	8600	10200	11900
6070			
188	202	216	230
7349			
2	4	4	6
7369			
2	4	4	6
All Models			
1002 x2			
1006 x2			
1402 x2			
1403 x2			
1405 x2			
1409 x2			
1412 x2			
1415 x2			
3002 x2			
7052 x6			
7053 x4			
7359 x1			
7370 x1			
7371 x1			

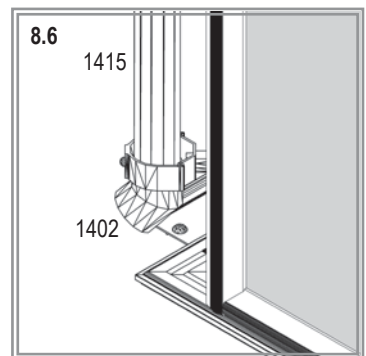
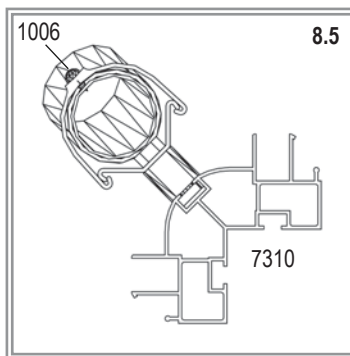
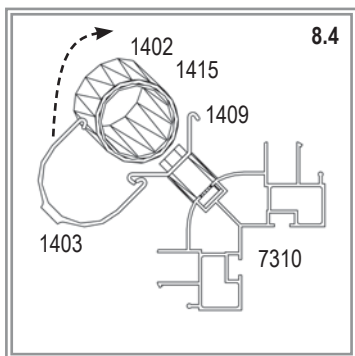
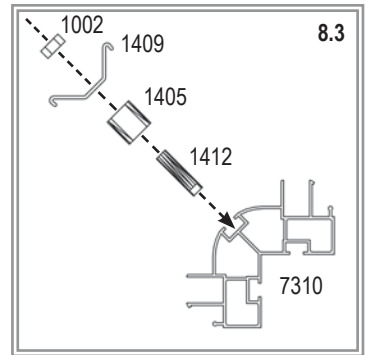
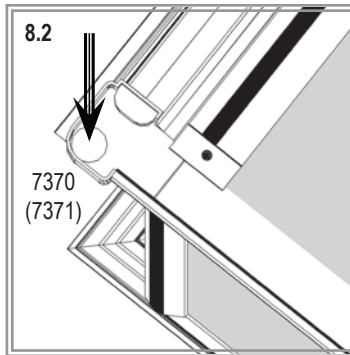
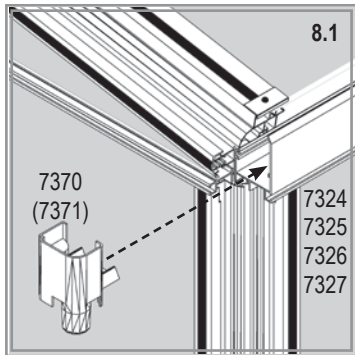
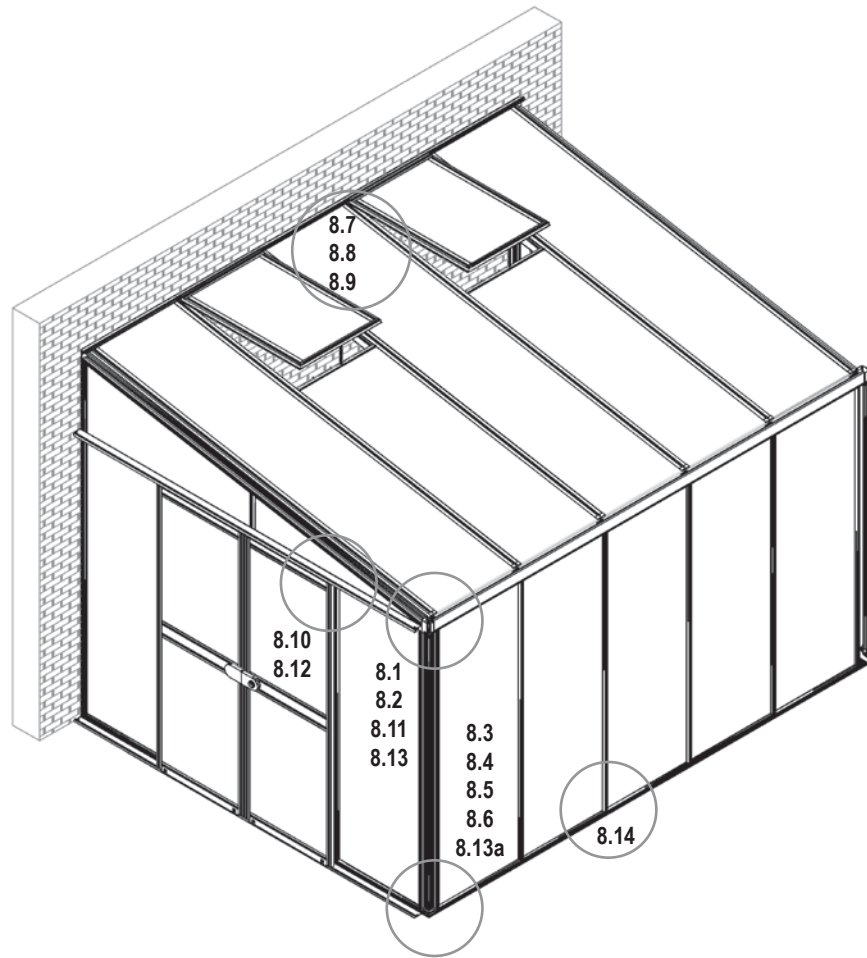

HELENA

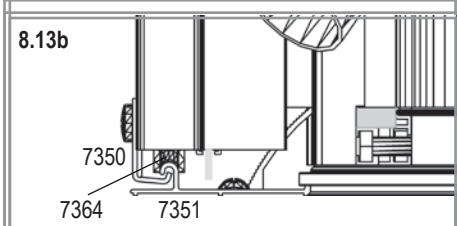
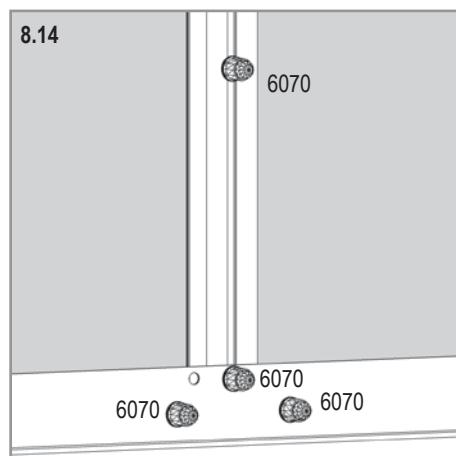
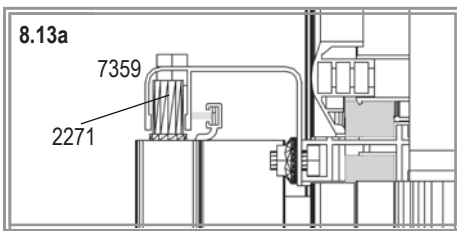
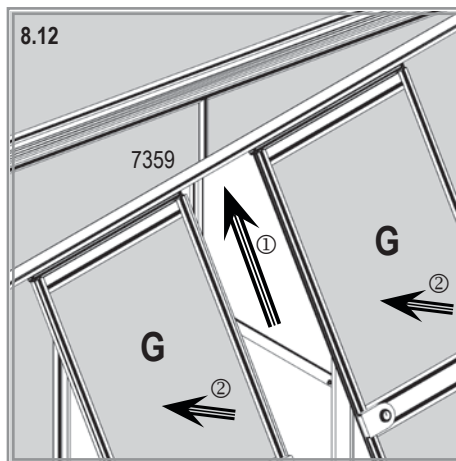
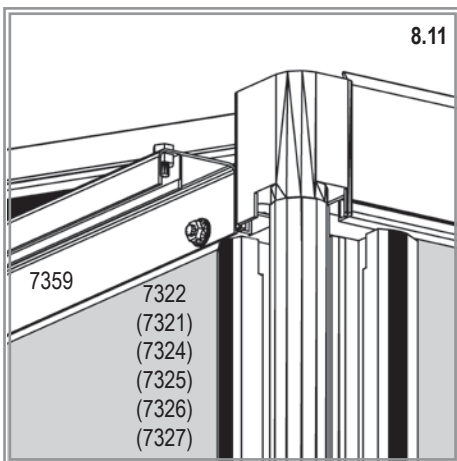
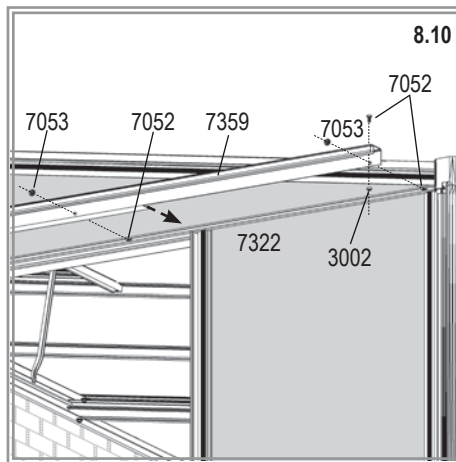
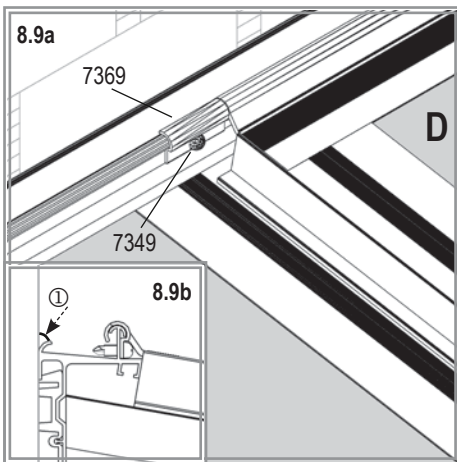
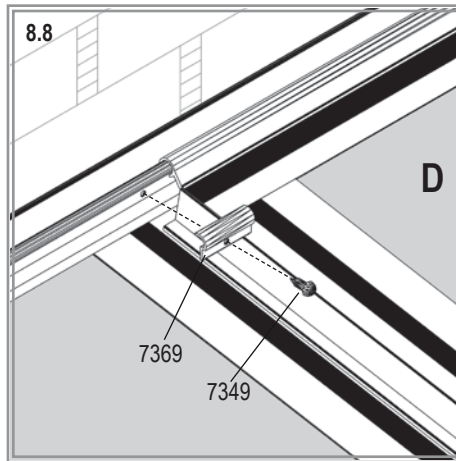
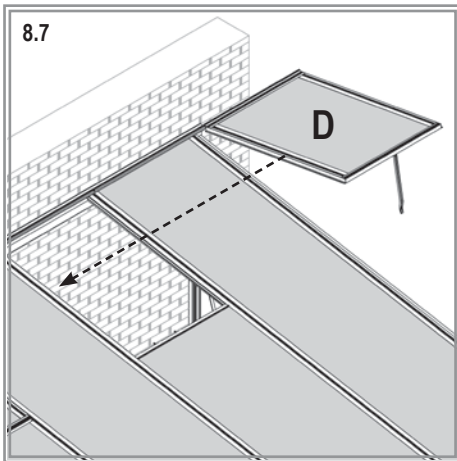



E.P.H. Schmidt u. Co. GmbH
Hoefkerstrasse 30
44149 Dortmund
Postfach 170163
44060 Dortmund
Deutschland
Tel.: +49 231 941655 0
Fax: +49 231 941655 99
www.eph-schmidt.de
verkauf@eph-schmidt.de

OPJ A/S
Volderslevvej 36 A
Postboks 480
5260 Odense S
Danmark
Tel.: +45 66 15 10 30
Fax: +45 66 15 00 84
www.opj.dk
opj@opj.dk