



blumfeldt



## Pantheon

Pergola

10031884 10031885 10035879 100358780  
10035891 10035892



**Sehr geehrter Kunde,**

wir gratulieren Ihnen zum Erwerb Ihres Gerätes. Lesen Sie die folgenden Hinweise sorgfältig durch und befolgen Sie diese, um möglichen Schäden vorzubeugen. Für Schäden, die durch Missachtung der Hinweise und unsachgemäßen Gebrauch entstehen, übernehmen wir keine Haftung. Scannen Sie den folgenden QR-Code, um Zugriff auf die aktuellste Bedienungsanleitung und weitere Informationen rund um das Produkt zu erhalten:

**Dear Customer,**

Congratulations on purchasing this device. Please read the following instructions carefully and follow them to prevent possible damages. We assume no liability for damage caused by disregard of the instructions and improper use. Scan the QR code to get access to the latest user manual and more product information.

**Estimado cliente,**

Le felicitamos por la adquisición de este producto. Lea atentamente las siguientes instrucciones y sígalas para evitar posibles daños. No asumimos ninguna responsabilidad por los daños causados por el incumplimiento de las instrucciones y el uso inadecuado. Escanee el siguiente código QR para obtener acceso a la última guía del usuario y más información sobre el producto.

**Chère cliente, cher client,**

Toutes nos félicitations pour l'acquisition de ce nouvel appareil. Veuillez lire attentivement et respecter les instructions de ce mode d'emploi afin d'éviter d'éventuels dommages. Nous ne saurions être tenus pour responsables des dommages dus au non-respect des consignes et à la mauvaise utilisation de l'appareil. Scannez le QR-Code pour obtenir la dernière version du mode d'emploi et des informations supplémentaires concernant le produit.











**Gentile cliente,**

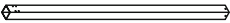
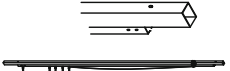



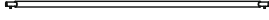

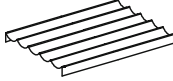



La ringraziamo per aver acquistato il dispositivo. La preghiamo di leggere attentamente le seguenti istruzioni per l'uso e di seguirle per evitare possibili danni. Non ci assumiamo alcuna responsabilità per danni scaturiti da una mancata osservazione delle avvertenze di sicurezza e da un uso improprio del dispositivo. Scansionare il codice QR seguente, per accedere al manuale d'uso più attuale e per ricevere informazioni sul prodotto.



# LIEFERUMFANG

Scope of delivery | Volumen de suministro | Contenu de la livraison |  
Dotazione di fornitura

 A x 2	 B x 2	 C x 1
 D x 1PC	 E x 1	 F x 2
 G x 6	 H x 4	 J x 5
 K x 10	 L x 1	 M x 2

 <b>Ox8</b>	 <b>Px 6</b>	 <b>Q x 6</b>	 <b>R x 20</b>
 <b>M6x15 mm</b> <b>① x 24</b>	 <b>M6x 45 mm</b> <b>② x 40</b>	 <b>M6x 75 mm</b> <b>③ x 22</b>	 <b>④ x 12</b>
  <b>⑤ x 1</b>			

# ZUSAMMENBAU

Assembly | Ensamblaje | Assemblée | Assemblaggio

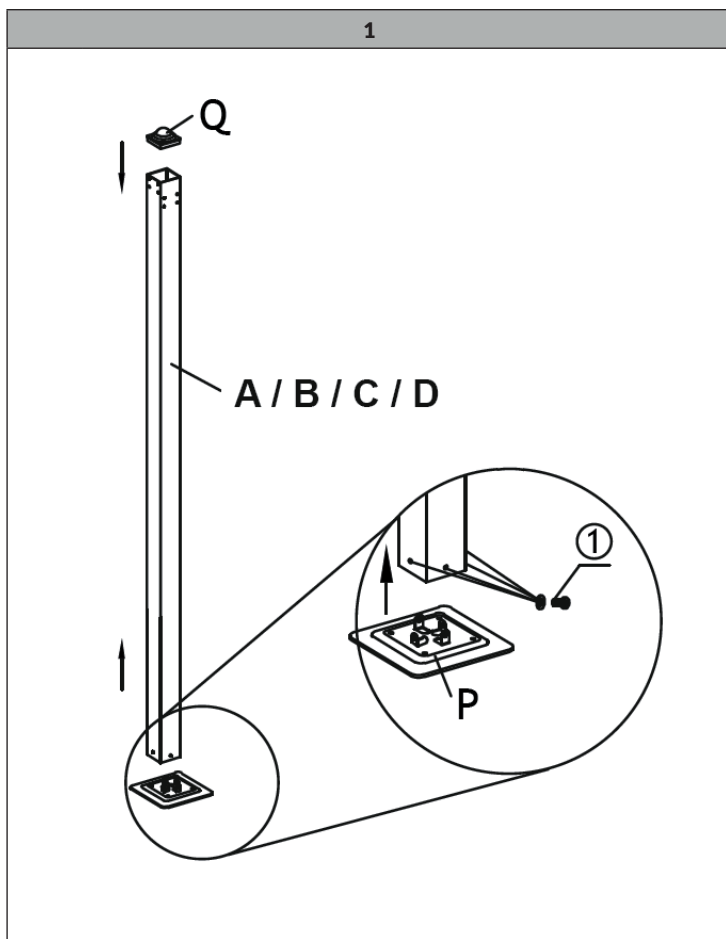

**DE** Wiederholen Sie den Vorgang an allen 4 Pfosten.

**EN** Repeat the process on all 4 posts.

**ES** Repita el proceso en los 4 postes.

**FR** Répétez l'opération sur les 4 poteaux.

**IT** Ripetere l'operazione su tutti e 4 i pali.

2

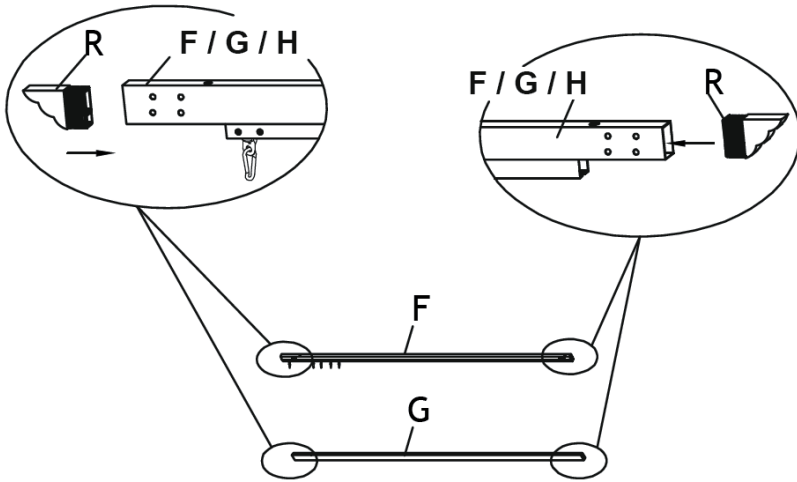

3

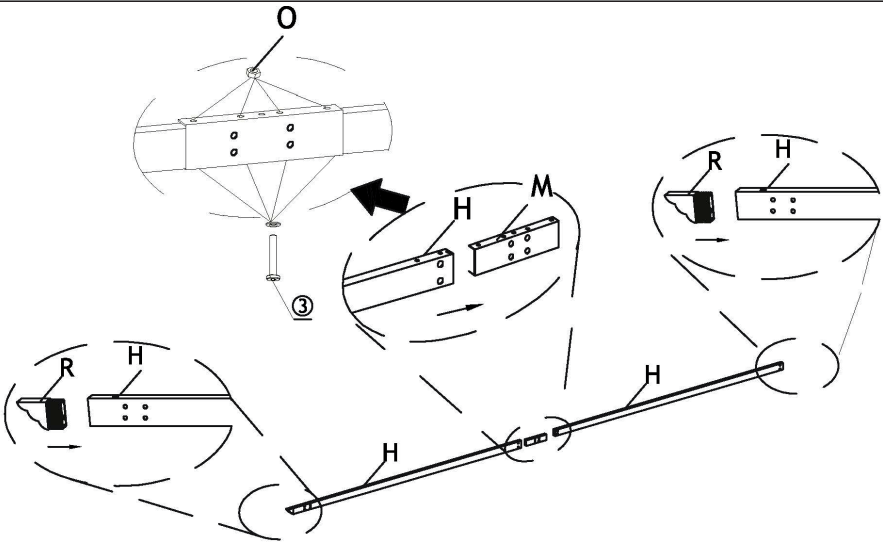

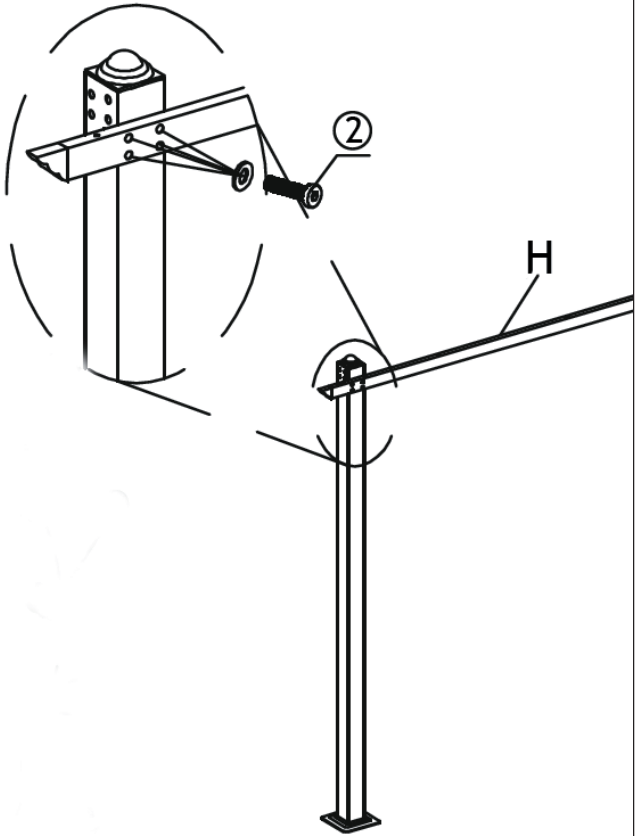



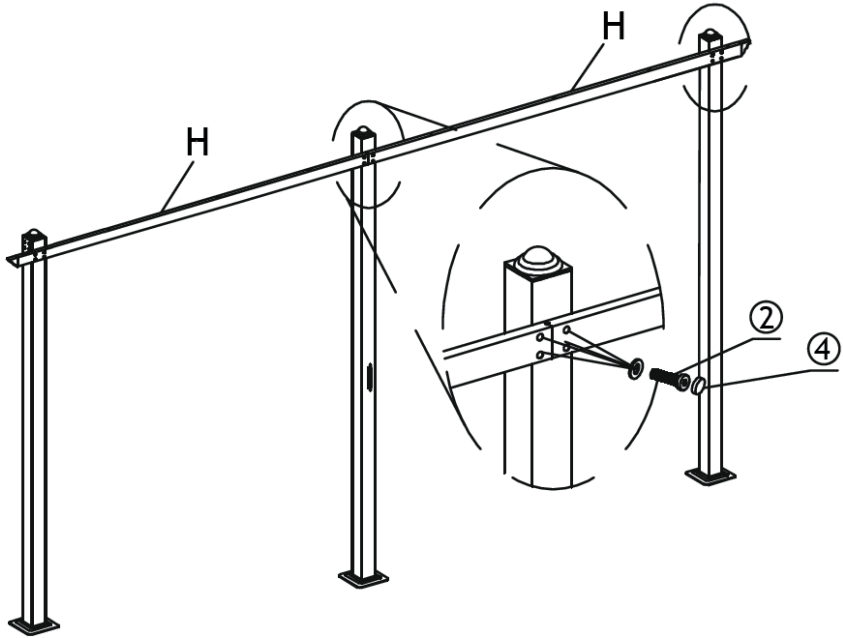

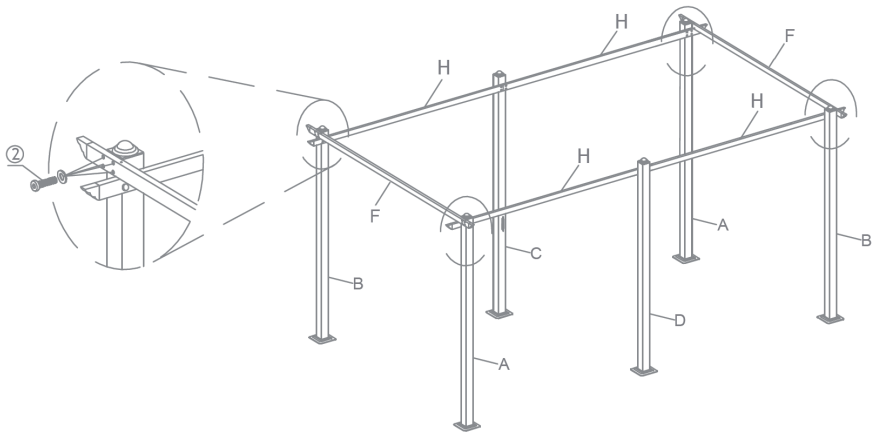

<b>DE</b>	Befestigen Sie den Querbalken F zuerst mit Schraube (2) samt Unterlegscheibe. Setzen Sie dann O ein. Wiederholen Sie diesen Vorgang an allen 4 Eckpfosten.
<b>EN</b>	First fasten the crossbar F with screw (2) including washer. Then insert O. Repeat this process on all 4 corner posts.
<b>ES</b>	En primer lugar, fije el travesaño F con el tornillo (2) y la arandela. Luego inserta O. Repita este procedimiento en los 4 postes esquineros.
<b>FR</b>	Fixez d'abord la barre transversale F avec la vis (2) et la rondelle. Insérez ensuite O. Répétez cette opération pour les 4 poteaux d'angle.
<b>IT</b>	Fissare prima la traversa F con la vite (2) e la rondella. Quindi inserire O. Ripetere questa procedura su tutti e 4 i montanti d'angolo.

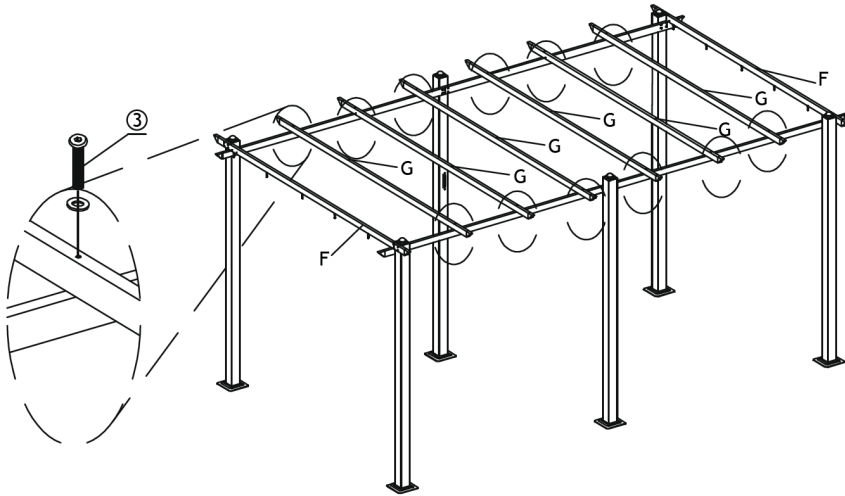

<b>DE</b>	Befestigen Sie den Querbalken G mit Schraube (3) samt Unterlegscheibe. Wiederholen Sie diesen Vorgang an allen Enden, die mit einem Kreis markiert sind.
<b>EN</b>	Fasten the crossbar G with screw (3) including washer. Repeat this procedure at all ends marked with a circle.
<b>ES</b>	Fije el travesaño G con el tornillo (3) y la arandela. Repita este procedimiento en todos los extremos marcados con un círculo.
<b>FR</b>	Fixez la barre transversale G avec la vis (3) et la rondelle. Répétez cette opération à toutes les extrémités marquées d'un cercle.
<b>IT</b>	Fissare la traversa G con la vite (3) e la rondella. Ripetere questa procedura su tutte le estremità contrassegnate da un cerchio.

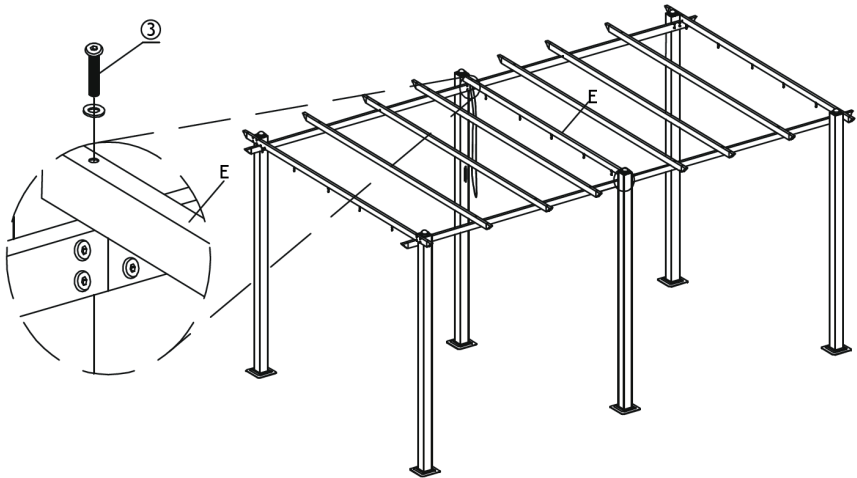

<b>DE</b>	Befestigen Sie den Querbalken G mit Schraube (3) samt Unterlegscheibe. Wiederholen Sie diesen Vorgang auf der gegenüberliegenden Seite.
<b>EN</b>	Fasten the crossbar G with screw (3) including washer. Repeat this procedure on the opposite side.
<b>ES</b>	Fije el travesaño G con el tornillo (3) y la arandela. Repita este procedimiento en el lado opuesto.
<b>FR</b>	Fixez la barre transversale G avec la vis (3) et la rondelle. Répétez cette opération sur le côté opposé.
<b>IT</b>	Fissare la traversa G con la vite (3) e la rondella. Ripetere la procedura sul lato opposto.9

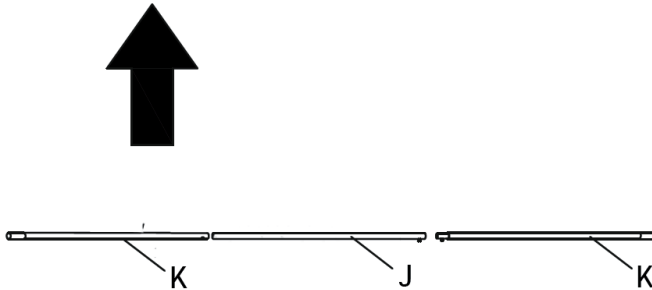
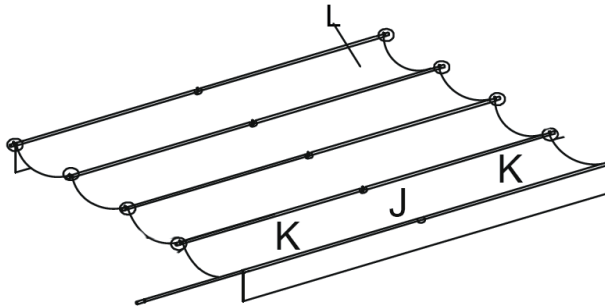

<b>DE</b>	Schieben Sie das Teil N auf die Stäbe K und schieben Sie N bis zum Ende des Stabs durch. Stecken Sie dann die Stäbe K / J / K zusammen. Schieben Sie den fertigen Stab dann in die Markiese. Wiederholen Sie diesen Vorgang für alle 5 Stäbe.
<b>EN</b>	Slide part N onto rods K and push N through to the end of the rod. Then put the rods K / J / K together. Then push the finished rod into the marker. Repeat this process for all 5 rods.
<b>ES</b>	Deslice la pieza N en la varilla K y empuje N hasta el final de la varilla. Luego junta las varillas K / J / K. A continuación, introduce la varilla terminada en el marcador. Repita este proceso con las 5 varillas.
<b>FR</b>	Glisse la pièce N sur les tiges K et enfonce N jusqu'à l'extrémité de la tige. Emboîtez ensuite les tiges K / J / K. Glissez ensuite la tige terminée dans le repère. Répétez cette opération pour les 5 tiges.
<b>IT</b>	Far scorrere la parte N sull'asta K e spingere N fino all'estremità dell'asta. Quindi unire le aste K / J / K. Quindi spingere l'asta finita nel marcatore. Ripetere questo procedimento per tutte e 5 le aste.

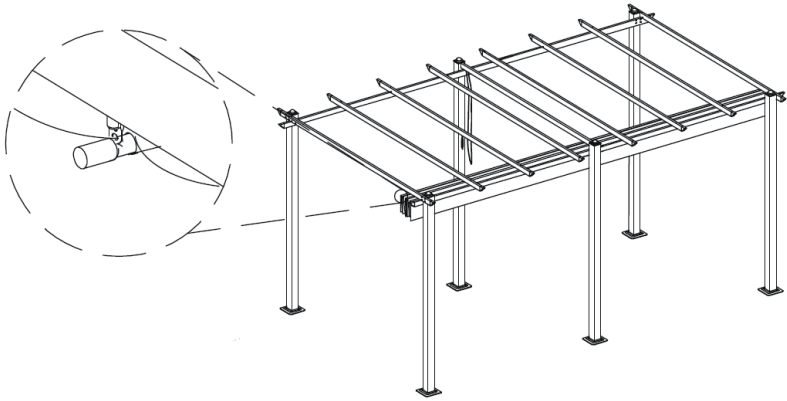

<b>DE</b>	Wiederholen Sie diesen Vorgang auch auf der anderen Seite der Markise.
<b>EN</b>	Repeat this procedure on the other side of the awning as well.
<b>ES</b>	Repita este proceso también en el otro lado del toldo.
<b>FR</b>	Répétez cette opération de l'autre côté du store.
<b>IT</b>	Ripetere l'operazione anche sull'altro lato della tenda.

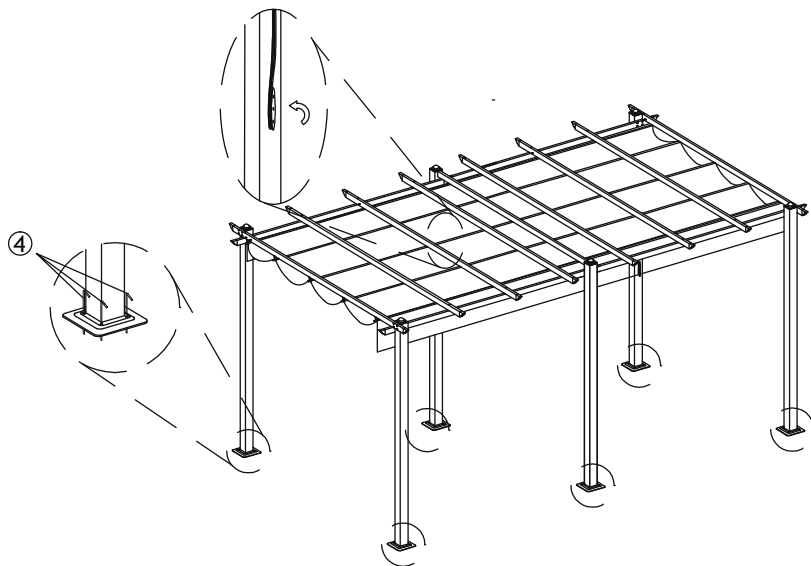

<b>DE</b>	Verankern Sie zum Schluss alle 6 Pfosten mit je 4 Erdnägeln (4).
<b>EN</b>	Finally, anchor all 6 posts with 4 ground nails each (4).
<b>ES</b>	Por último, ancle los 6 postes con 4 clavos de tierra cada uno (4).
<b>FR</b>	Pour finir, ancrez les 6 poteaux avec 4 piquets (4) chacun.
<b>IT</b>	Infine, ancorare tutti e 6 i pali con 4 chiodi a terra ciascuno (4).





---

## **HERSTELLER**

---

**Manufacturer | Fabricante | Fabricant | Produttore**

Chal-Tec GmbH, Wallstraße 16, 10179 Berlin, Deutschland (Germany).

---

## **IMPORTEUR FÜR GROSSBRITANNIEN**

---

**Importer for Great Britain | Importador para Gran Bretaña | Importateur pour la Grande Bretagne | Importatore per la Gran Bretagna**

Berlin Brands Group UK Limited  
PO Box 42  
272 Kensington High Street  
London, W8 6ND  
United Kingdom





