

Yardmaster

INTERNATIONAL

0409

Please Direct Enquires To:
Yardmaster International
Cahore Road
Draperstown
BT45 7AP.
Tel: 028 796 28449

Demandes de renseignements à:
TRIGANO JARDIN
Service Commercial
Usine du Boulay
41170 Cormenon.
Mondoubleau.
Tel: (02) 54 73 55 55

Bitte alle Anfragen an:
I.N.I.
Kaistraße 7-9
40221 Düsseldorf.
Tel: 0211 30 21 28 15

**Assembly
Instructions**

**Montageanweisungen
Metallgerätekäuser**

**Notice de montage
Abri de Jardin Métallique**

**Opbouwbeschrijving
Metalen Bergingen**

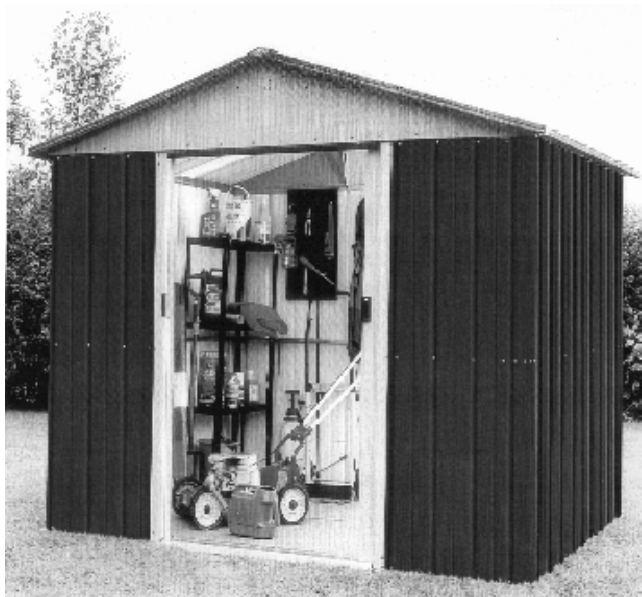

GREEN VERT GRÜN	
MODEL 87 GEYZ	
MODEL 87 GHZ	
SILVER	
MODEL 87 ZGEY	

PARTS LIST	ONDERDELENLIJST	PART NO.	LENGTH		
PART DESCRIPTION	BESCHRIJVING VAN DE		87	MM	
600 mm Wall Panel	600mm Wandpaneel	101	8	1600	
Corner Panel	Hoekpaneel	103.04	4	1600	
Door Post	Deurstijl	106.02	2	1600	
Inter-Roof Panel	Dak-Tussenplaat	201.24	2	1215	
Narrow Inter-Roof Panel	Smalle Dak-Tussenplaat	202.24	4	1215	
Left Hand Front/Right Hand Rear	Dakplaat Linksvoor/Rechtsachter	203.23	2	1215	
Right Hand Front/Left Hand Rear	Dakplaat Rechtsvoor/Linksachter	204.23	2	1215	
Gable Left Hand Front/Right	Geveltop-Linksvoor/Rechtsachter	301	2	920	
Gable Right Hand Front/Left	Geveltop- Rechtsvoor/Linksachter	302	2	920	
Centre Gables	Geveltoppen-Midden	305.24	2	395	
Base Rail	Funderingsrail	401.10	2	1033	
Base Rail	Funderingsrail	401.14	4	1233	
Side Brace	Zijklamp	402.10	5	965	
Side Brace	Zijklamp	402.14	1	1165	
Side Brace Splice	Zijklamp	402.89	3	370	
Front Brace	Voorklamp	403.24EA	2	565	
Corner Gusset	Hoekinzetstuk	406	4	86	
Notched Corner Gusset	Hoekinzetstuk	406EA	4	86	
Corner Gusset Stiffner	Versterking Van Hoekinzetstuk	407	2	150	
Anchor Bracket	Verankerung Steun	407EA	2	69	
Front Door Guide	Deurgeleider Linksbuiten	408409.24EA	2	733	
Side Beam	Zijbalk	501.10	2	1034	
Side Beam	Zijbalk	501.14	2	1234	
Roof Beam	Dakbalk	502.10	4	1034	
Roof Beam	Dakbalk	502.14	4	1234	
Ridge Cover	Nokplaat	503.02	1	615	
Ridge Cover	Nokplaat	503.03	1	415	
Ridge Cover	Nokplaat	503.07	1	490	
Ridge Cover	Nokplaat	503.08	1	690	
Roof Angle	Regengoot	504.01	2	1015	
Roof Angle	Regengoot	504.02	2	1365	
Left Hand Roof Beam Gusset	Linkersteunplaat Nokbalk	505	2	145	
Right Hand Roof Beam Gusset	Rechtersteunplaat Nokbalk	506	2	145	
Ridge Cover Cap	Nokplaat Eindstuk	507	2	160	
Left Hand Gutter End Cap	Eindkap Linkerregengoot	5081	2	45	
Right Hand Gutter End Cap	Eindkap Rechterregengoot	5091	2	45	
Left Hand Door	Linkerdeur	601.23	1	1593	
Right Hand Door	Rechter deur	602.23	1	1593	
Door Track	Deurrail	603.62	2	1090	
Gable Brace	Geveltop-Klamp	603.12	4	1095	
Door Slider	Deurrolletje En Steun	607.1	4	30	
Door Brace	Deurklamp	620.24	6	525	
Door Spacer	Deurhoekstuk	607EA	2	25	
Door Saddle	Deurslede	608.24EA	1	1016	
Door Handle	Deurhendel	609	2	100	
Door Pelmet	Raambedekking	615.03	1	1064	

LISTE DE PIECES	TEILE-LISTE	PART NO.	LENGTH		
			87	MM	
DESCRIPTION DE LA PIECE	TEILE-BEZEICHNUNG				
Panneau Mural 600mm	600mm Wandplatten	101	8	1600	
Panneau D'angle	Eckplatten	103.04	4	1600	
Montant De Porte	Türpfosten	106.02	2	1600	
Panneau Toit (Milieu)	Dach-Zwischenplatten	201.24	2	1215	
Panneau Toit (Milieu) Étroit	Schmale Dach-Zwischenplatten	202.24	4	1215	
Panneau Toit Avant Gauche/Arrière	Linke Vordere Bzw. Hintere Rechte	203.23	2	1215	
Panneau Toit Avant Droite/Arrière	Rechte Vordere Bzw. Hintere Linke	204.23	2	1215	
Pignon-Avant Gauche/Arrière Droite	Giebel-Vorne Links Bzw. Hinten	301	2	920	
Pignon-Avant Droite/Arrière Gauche	Giebel-Vorne Rechts Bzw. Hinten	302	2	920	
Pignons Centraux	Mittel-Giebel	305.24	2	395	
Rail Base	Grundleiste	401.10	2	1033	
Rail Base	Grundleiste	401.14	4	1233	
Cornières Latéral	Seitenstütze	402.10	5	965	
Cornières Latéral	Seitenstütze	402.14	1	1165	
Cornières Latéral	Seitenstütze	402.89	3	370	
Cornières Avant	Vorderstütze	403.24EA	2	565	
Renfort D'angle Arrière	Hintere Eckenwinkel	406	4	86	
Renfort D'angle Avant	Vordere Eckenwinkel	406EA	4	86	
Kit D'ancrage	Eckenwinkelversteifung	407	2	150	
Piece D'ancrage	Verankerung Teil	407EA	2	69	
Guide De Porte Extérieur Gauche	Linke äußere Türführung	408409.24EA	2	733	
Poutre Latérale	Seitenträger	501.10	2	1034	
Poutre Latérale	Seitenträger	501.14	2	1234	
Poutre Toit	Dachträger	502.10	4	1034	
Poutre Toit	Dachträger	502.14	4	1234	
Faîtière	Firstverkleidung	503.02	1	615	
Faîtière	Firstverkleidung	503.03	1	415	
Faîtière	Firstverkleidung	503.07	1	490	
Faîtière	Firstverkleidung	503.08	1	690	
Gouttière d,angle	Dachtraufverkleidung	504.01	2	1015	
Gouttière d,angle	Dachtraufverkleidung	504.02	2	1365	
Gousset De Poutre Faîtière Gauche	Linke Firsträgerwinkel	505	2	145	
Gousset De Poutre Faîtière Droite	Rechte Firsträgerwinkel	506	2	145	
Cache Plastique Toiture	Firstverkleidungskappe	507	2	160	
Embout D'Extrémité De Gouttière	Linke Dachrinnen-Endkappen	5081	2	45	
Embout D'Extrémité De Gouttière	Rechte Dachrinnen-Endkappen	5091	2	45	
Porte Gauche	Linke Tür	601.23	1	1593	
Porte Droite	Rechte tür	602.23	1	1593	
Glissière De Porte	Türschiene	603.62	2	1090	
Glissière De Pignon	Giebel-Vorne Balken	603.12	4	1095	
Coulisseau Haut	Türschieber	6071	4	30	
Porte Renforcee	Türstütze	620.24	6	525	
Ecarteur De Porte	Tür-Distanzschiebe	607EA	2	25	
Bride De Porte	Türschwelle	608.24EA	1	1016	
Poignée De Porte	Türgriff	609	2	100	
Pièce de Junction	Verbindung Teil	61503	1	1064	

WALL PANEL PANNEAU MURAL WANDPLATTEN WANDPANEEL

408409.24EA

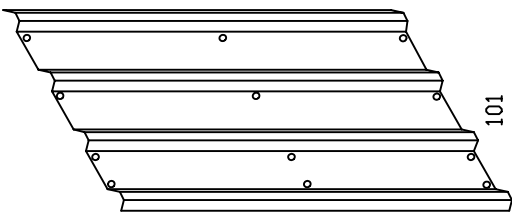

101

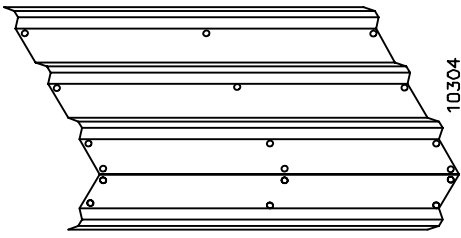

10304

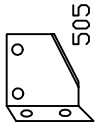

505

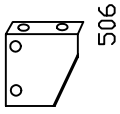

506

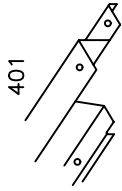

401

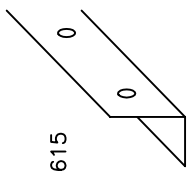

615

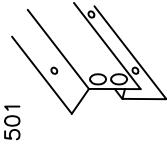

501

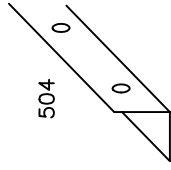

504

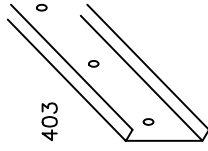

403

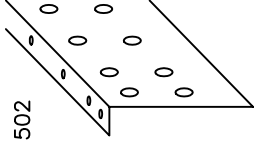

502

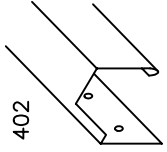

402

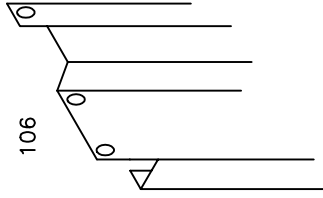

106

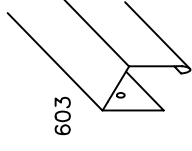

603

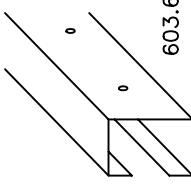

603.62

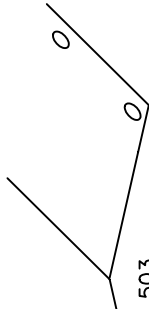

503

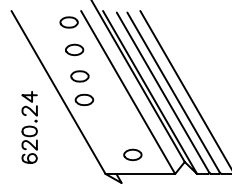

620.24

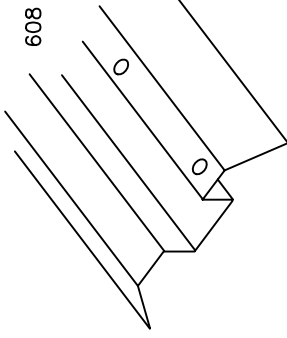

608

ROOF PANEL PANNEAU TOIT DACHPLATTE DAKPLAAT

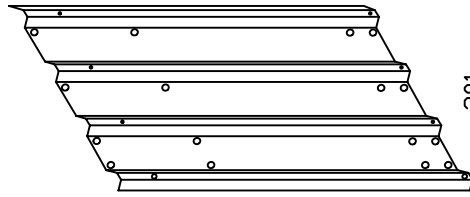

201



202

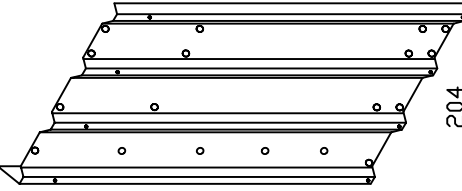

204

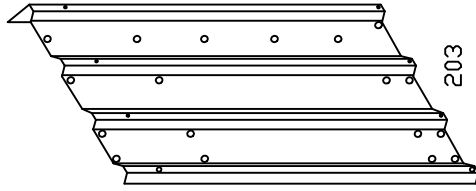

203

305.24

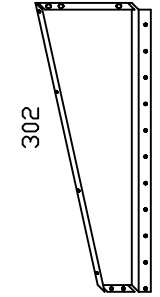

302

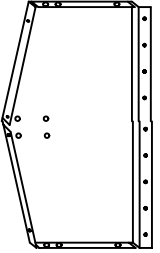

301

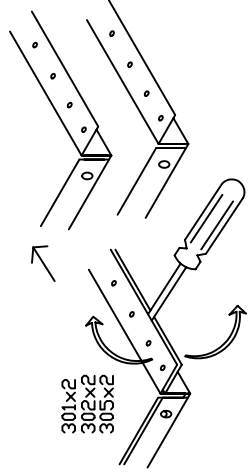

301x2
302x2
305x2

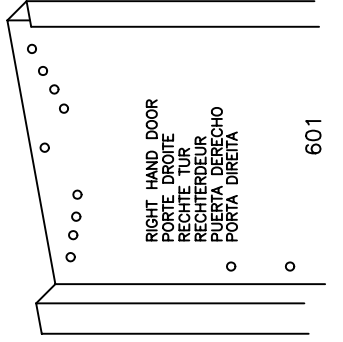

RIGHT HAND DOOR
PORTE DROITE
RECHTE TUR
RECHTERDEUR
PUERTA DERECHO
PORTA DIRETTA

601

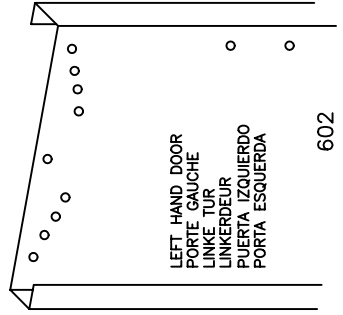

LEFT HAND DOOR
PORTE GAUCHE
LINKE TUR
LINKERDEUR
PUERTA IZQUIERDO
PORTA ESQUERDA

602

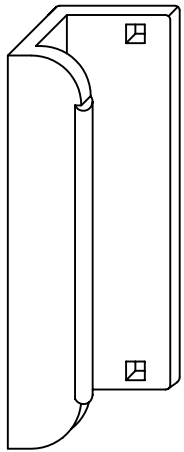

609 x 2

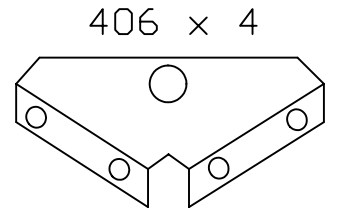
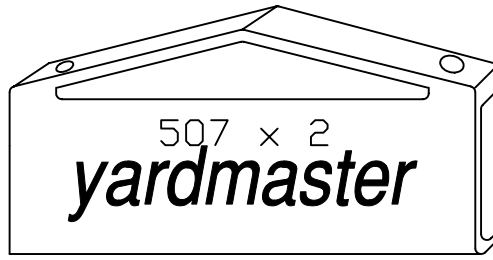

406 x 4

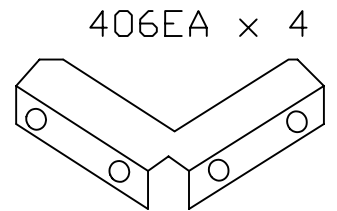

406EA x 4

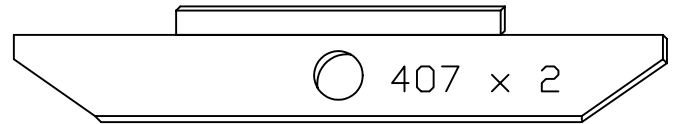
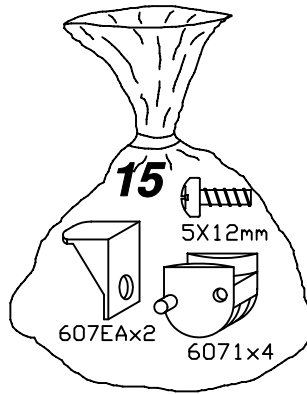

407 x 2

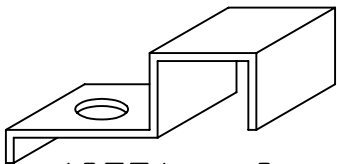

407EA x 2

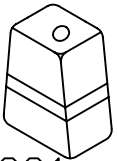

5081

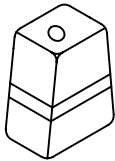

5091

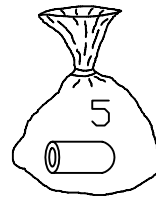

5

M5X12mm

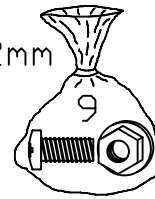

9

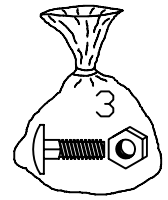

3

12X5mm X 4

11x4mm

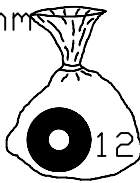

12



13

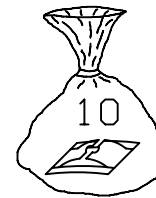

10

8X9mm

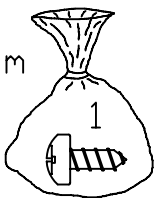

1

8X12mm

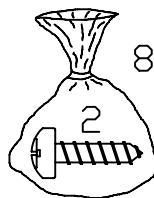

2

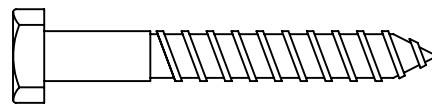

M8X50mm X 2



M8X70mm X 2

12x4mm

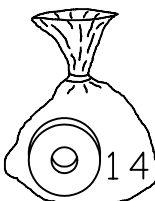

14

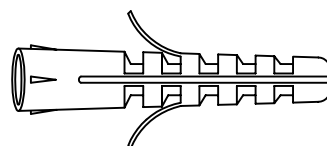

M10X50mm X 4

M8X19mm X 4

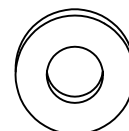

ASSEMBLY INSTRUCTIONS (ENGLISH) MODEL 87

Before starting, read through the assembly instructions carefully. Check thoroughly all the parts you have received against the parts list (page 1) and the diagram (page 3,4). Ensure that no parts are damaged.

THINGS TO REMEMBER !

- 1. WEATHER WARNING ! DO NOT ERECT YOUR BUILDING ON A WINDY DAY. ANY BUILDING LEFT PARTIALLY CONSTRUCTED MAY BE SERIOUSLY DAMAGED (Fig.1).**
- 2. ALWAYS ASSEMBLE THE ROOF FIRST ESPECIALLY IF YOU DO NOT INTEND TO COMPLETE CONSTRUCTION ON THE SAME DAY.**
- 3. ALL ASSEMBLY OPERATIONS MUST TAKE PLACE ON A COMPLETELY LEVEL SURFACE (Fig. 1)**
- 4. UNLESS OTHERWISE STATED SCREWS AND FIBRE WASHERS (BAGS 1 AND 12) MUST BE USED IN ALL ASSEMBLY OPERATIONS.**
- 5. IT IS RECOMMENDED THAT YOU WEAR THE GLOVES PROVIDED WHEN ASSEMBLING THIS PRODUCT.**
- 6. THE SHED SHOULD BE SECURELY ANCHORED TO A FIRM LEVEL BASE E.G. CONCRETE, PAVING SLABS, WOOD ETC FOR CONCRETE BASE SEE BELOW.**

SITE PREPARATION CONCRETE.

1. Concrete should be laid a minimum of 75mm thick and at least 100mm greater than the overall size of the metal base frame at approx. 25mm above ground level. A sheet of heavy duty polythene placed under the base area will help prevent dampness rising from the ground into the shed. For concrete base measurements see fig. 2.

NOTICE DE MONTAGE 87

Avant de commencer à lire attentivement la notice de montage, vérifiez précisément si vous avez bien reçu toutes les pièces énoncées sur la liste page 2, ainsi que sur le schéma page 3&4. Assurez vous qu'aucune pièce n'a été endommagée.

N'OUBLIEZ PAS !

- 1. TEMPÊTE DE VENT: NE JAMAIS MONTER VOTRE ABRI PAR GRAND VENT. NE PAS LAISSER**

UN ABRI PARTIELLEMENT MONTÉ, LES PIÈCES POUVANT ÊTRE ENDOMMAGÉES

(FIG. 1).

- 2. ASSEMBLER EN PRIORITÉ LE TOIT SURTOUT SI VOUS PENSEZ NE PAS FINIR LE MONTAGE DANS LA JOURNÉE.**
- 3. TOUTES LES OPÉRATIONS DE MONTAGE DOIVENT ÊTRE RÉALISÉES SUR UNE SURFACE PLANE (fig 1).**
- 4. UTILISER SUR TOUTES LES VIS À MÉTAUX D'ASSEMBLAGE (SAC NO 1) LES RONDELLES D'ÉTANCHÉITÉ EN FIBRE (SAC NO 12)**
- 5. L'ABRI DOIT ÊTRE FIXE AU SOL SUR UNE SURFACE PLANE, PAR EXEMPLE, BETON, DALLES EN BETON, BOIS ETC. POUR UNE SURFACE DE BETON, VOIR CI-DESSUS.**

PRÉPARATION DE LA DALLE:

1. Le béton doit être coulé sur une épaisseur de 75mm, et dépasser de 100mm la hauteur du profilé de base soit 25mm au dessus du niveau du sol. L'utilisation d'une toile de polythène épaisse et résistante, placée sous la base aidera à empêcher l'humidité de monter du sol dans l'abri. Pour les dimensions de la dalle en béton, vous reporter à la fig. 2.

MODELLE 87 MONTAGEANLEITUNG

VOR BEGINN:

1. Machen Sie sich mit den Montageanweisungen vertraut.
2. Überzeugen Sie sich an Hand der Teileliste (Seite 2) und der Schaubilder (seite 3 &4), ob alles vollständig ist und die Teile nicht beschädigt sind.

WICHTIG

- 1. STELLEN SIE DAS HAUS NICHT AN EINEM STÜRMISCHEN TAG AUF. JEDES HAUS WÜRDE UNTER SOLCHEN WETTERBEDINGUNGEN BESCHÄDIGT WORDEN.**
- 2. DER GARTENSCHUPPEN MUß AUF EINER VOLLSTÄNDIG EBENEN FLÄCHE ERRICHTET WERDEN.**
- 3. SOFERN NICHT ANDERS ANGEZEIGT BENÜTZEN SIE DIE SCHRAUBEN UND WASSERDICHTEN FASERSCHEIBEN (BEUTEL 1 & 12) BEI ALLEN MONTAGEGÄNGEN.**
- 4. TRAGEN SIE DIE BELIEFERTEN**

HANDSCHUHE BEI DER MONTAGE.

VORBEREITUNG DES BETONFUNDAMENTS:

Die Betonplattform soll mindestens 70-80mm stark und mindestens 100mm länger und breiter als der metall-grundrahmen sein. die plattform sollte außerdem mindestens 25mm über dem boden sein. Ein laken aus hochleistungskunststoff unter dem fundament wird dazu helfen, feuchtigkeit vorzubeugen, die von der erde in den schuppen hineindringt.

BOUWHANDLEIDING MODELLEN 87

Voordat U met de bouw begint, maakt U zich dan eerst goed vertrouwd met de bouwvoorwaarden. Kruis alle ontvangen onderdelen op de onderdelenlijst (pagina 1) en diagram (pagina 3&4) aan. Controleer of de onderdelen niet zijn beschadigd.

BELANGRIJK !

- 1 MONTEER UW SCHUUR NIET OP EEN WINDERIGE DAG. DE KANS DAT ER TÏDENS HET MONTEREN BESCHADIGINGEN ONTSTAAN IS DAN ZEER GROOT AANWEZIG (Afb 1).**
- 2 HET IS AAN TE RADEN , OM EERST HET DAK TE MONTEREN, VOORAL ALS U NIET VAN PLAN BENT OM HET COMPLETE SCHUURTJE IN EIN DAG TE MONTEREN.**
- 3 DE BOUW DIEN UITGEVOERD TE WORDEN OP EEN GEHEEL VLAKE ONDERGROND (Afb 1)**
- 4 TENZY ANDERS AANGEGEVEN MOETEN BIJ HET MONTEREN DE SCHROEVEN EN VEZELRINGEN UIT (Zak 1 en 12) WORDEN GEBR UIKT.**

VOORBEREIDING VAN DE BOUWPLAATS VAN BETON

- 1 Het beton dient minimaal 75mm dik te worden gelegd. Ongeveer 25mm boven grondniveau dient het beton minstens 100mm breder te zijn dan de totale maal van het metalen funderingsraam. Afb. 2.

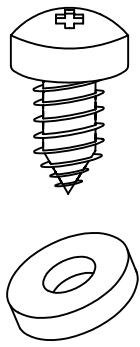

WASHERS TO BE USED ON ALL SCREWS
 VEZELRINGEN VOOR GEBRUIK ONDER ALLE SCHROEVEN
 RONDELLES POUR TOUTES LES VIS
 FASER SCHEIBEN FUR VERWENDUNG MIT ALLEN SCHRAUBEN
 ARANDELAS QUE DEBEN USARSE CON TODOS LOS TORNILLOS
 ANILHAS PARA SEREM UTILIZADAS EM TODOSMOS PARAFUSOS

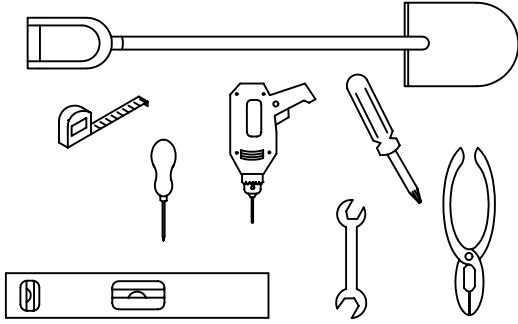

FIG. 1

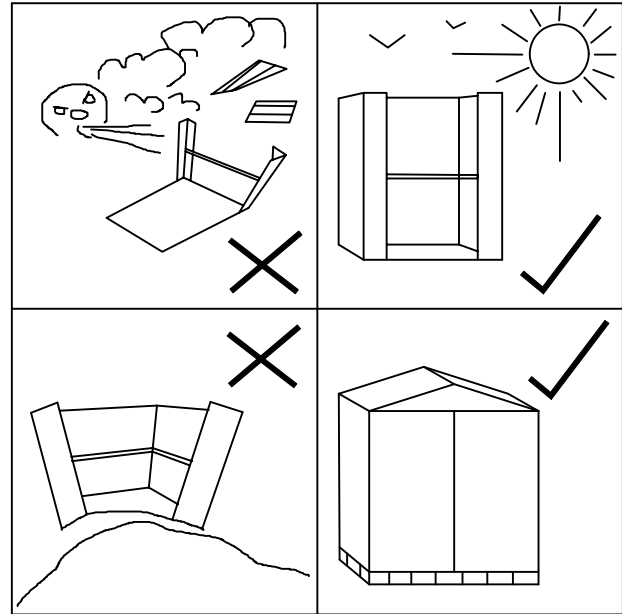
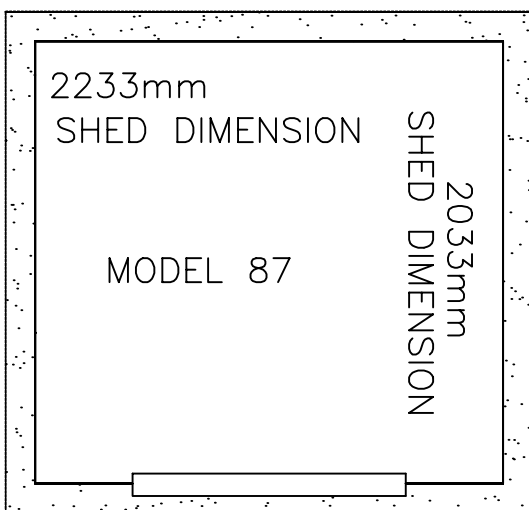

FIG. 2

2400mm
 BASE DIMENSION



FRONT DEVANT FREITE
 VOORKANT VORDERSEITE

2180mm
 BASE DIMENSION

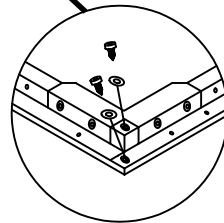
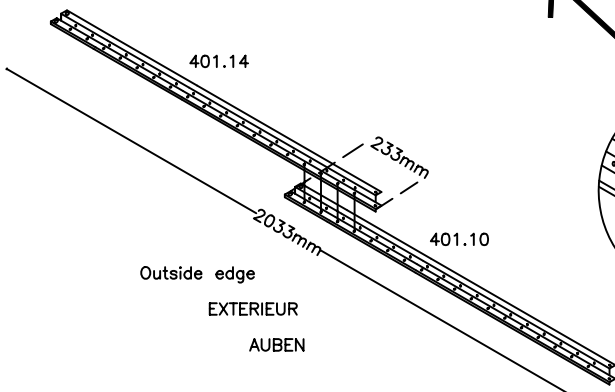
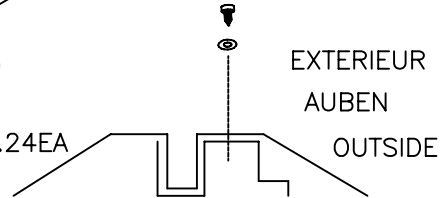
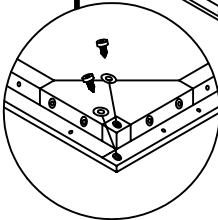
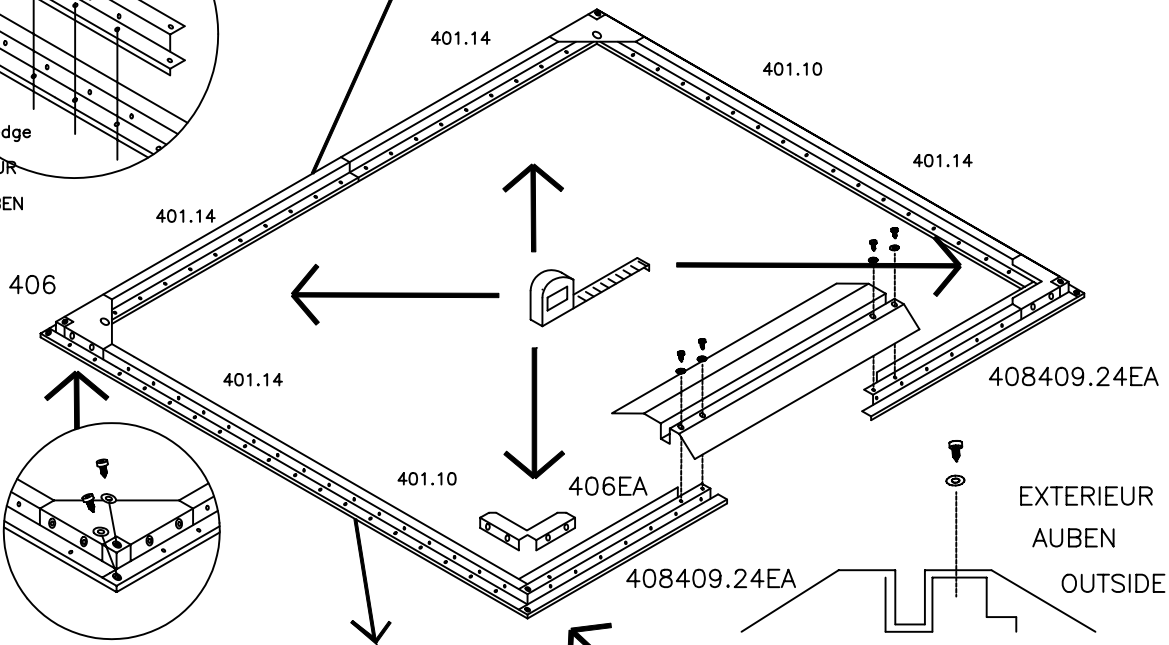
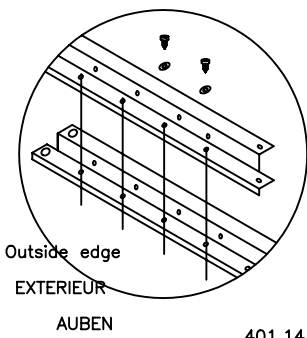
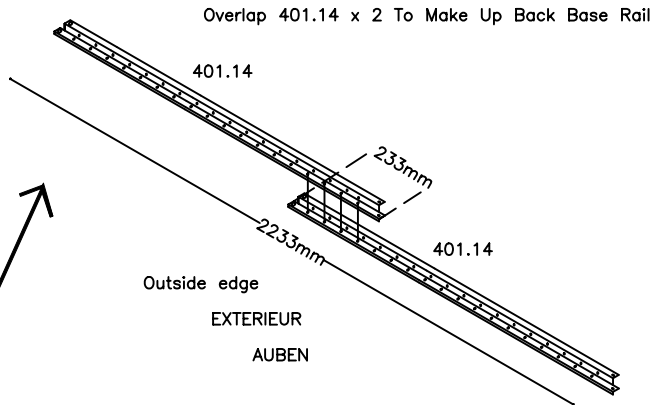
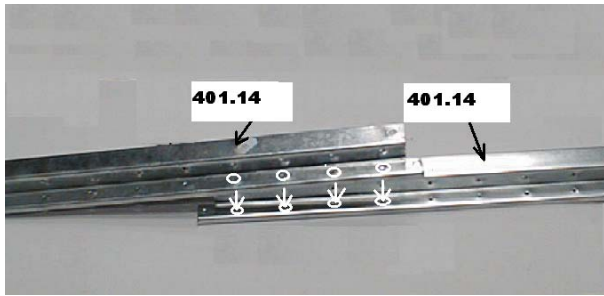

FRONT
VOORKANT
DEVANT
VORDERSEITE
FRENTE

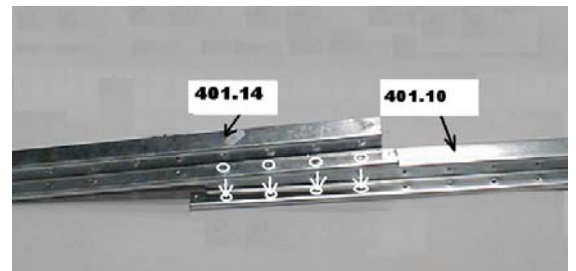

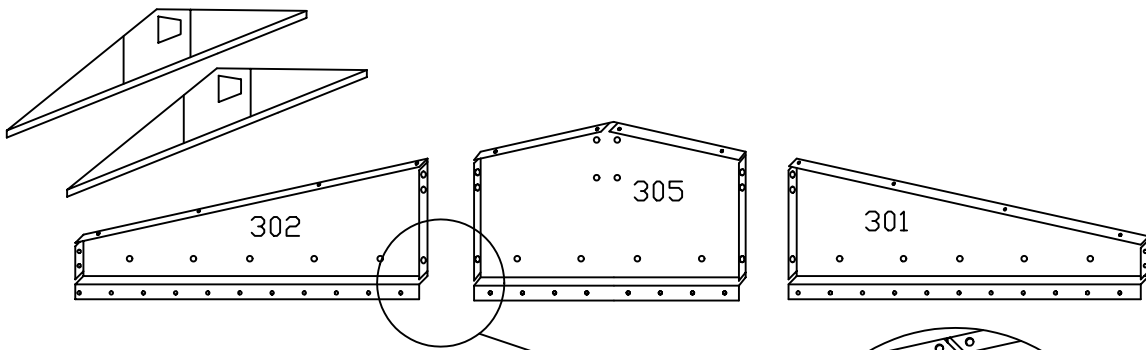

INSIDE VIEW
A L'INTERIEUR
INNENSEITE

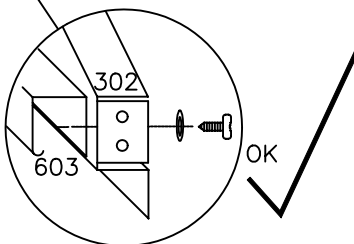
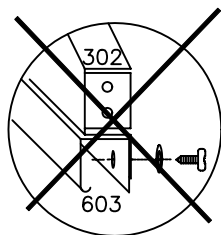
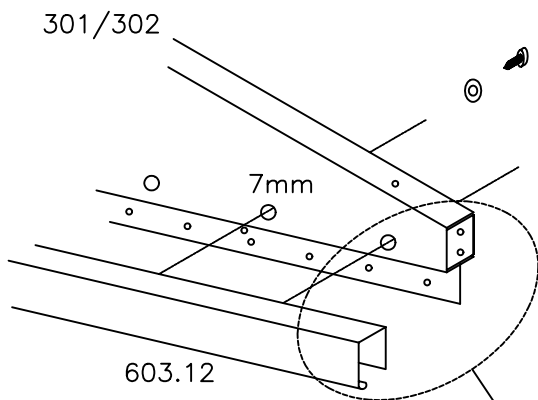
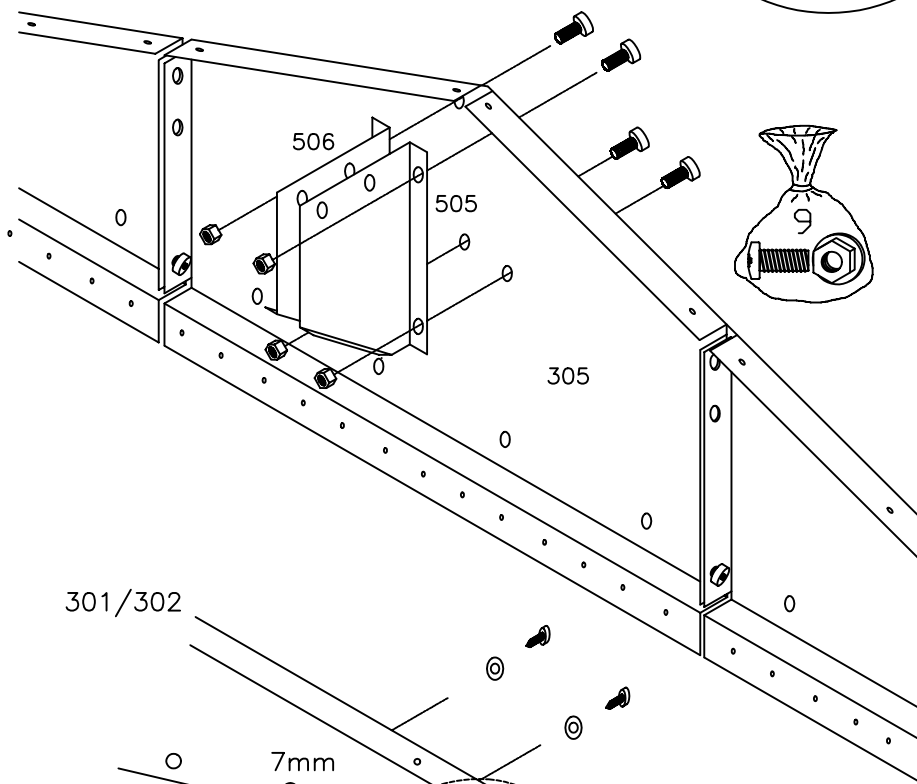
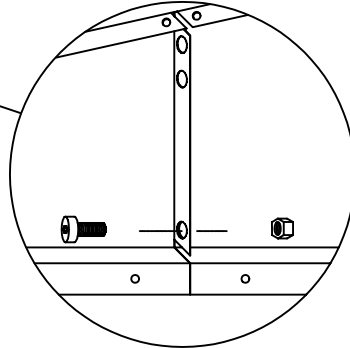
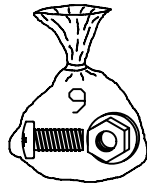

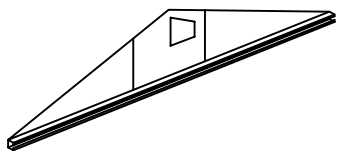

FRONT GABLES
 GEVELTOP-VOORKANT
 FACHADA FRONTAL
 PIGNON-AVANT
 GIEBEL-VORNE
 EMPENA FRONTAL

4 X



INSIDE VIEW
 A L'INTERIEUR
 INNENSEITE

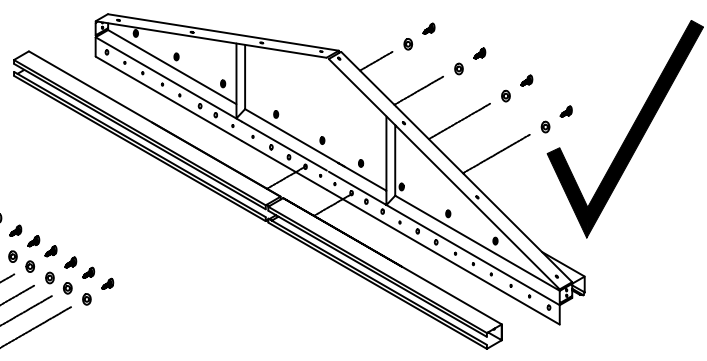
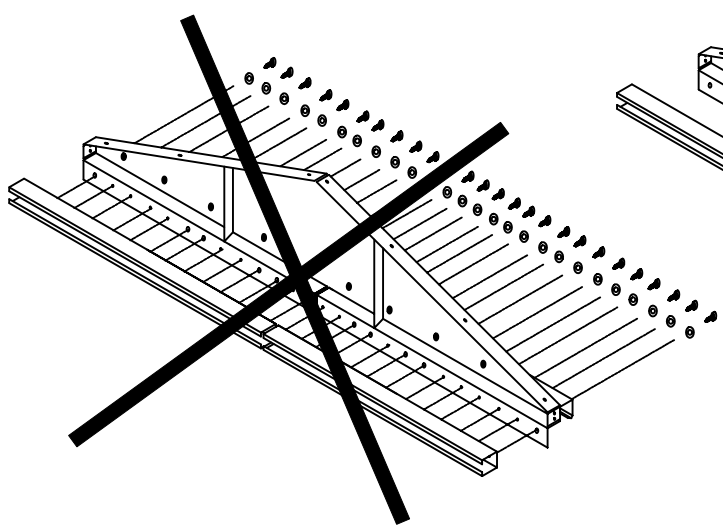
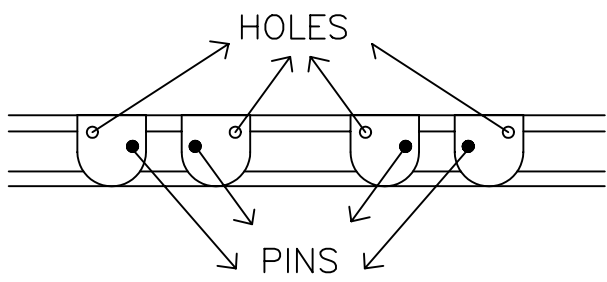
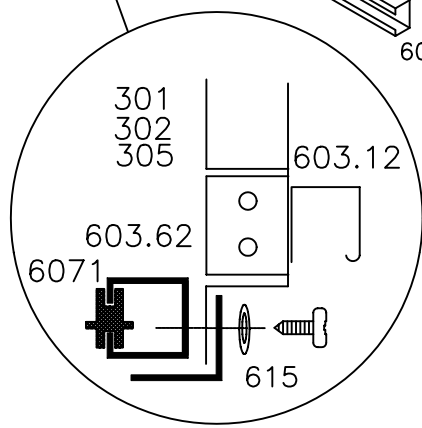
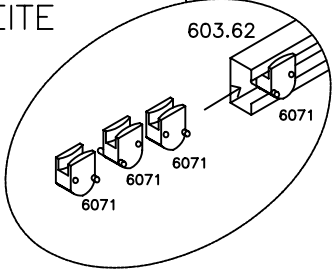
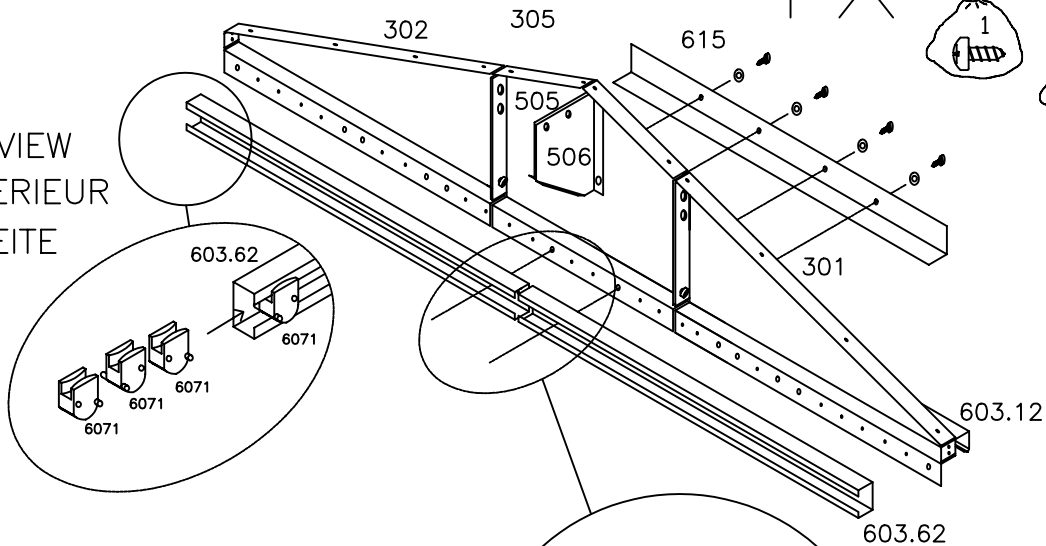

INSIDE VIEW
 A L'INTERIEUR
 INNENSEITE

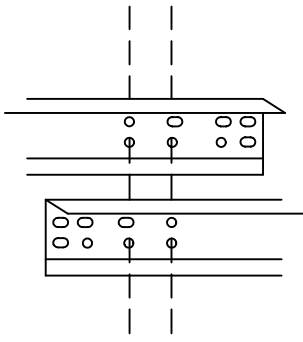

233 mm Overlap

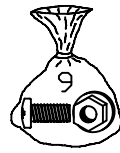

502.14

X 2

502.10

2034mm

X 1

502.14

502.14

502.10

502.10

2034mm

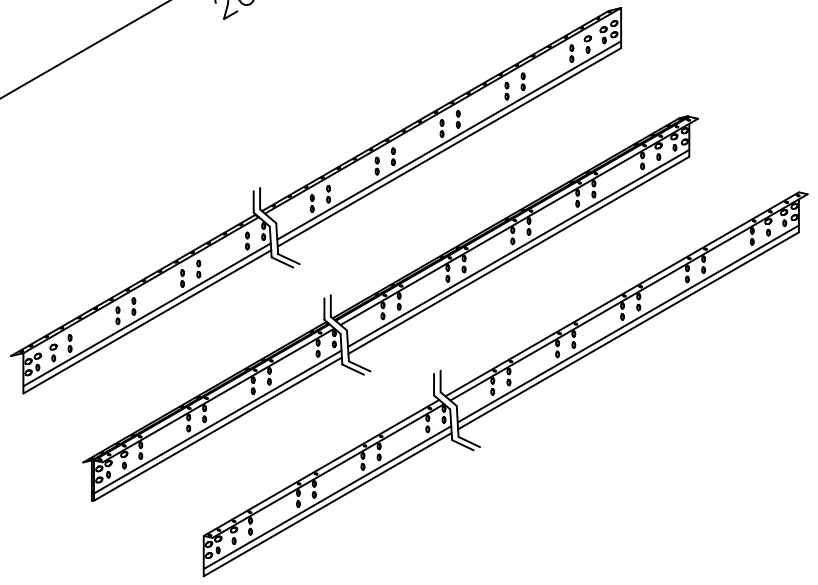
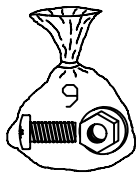

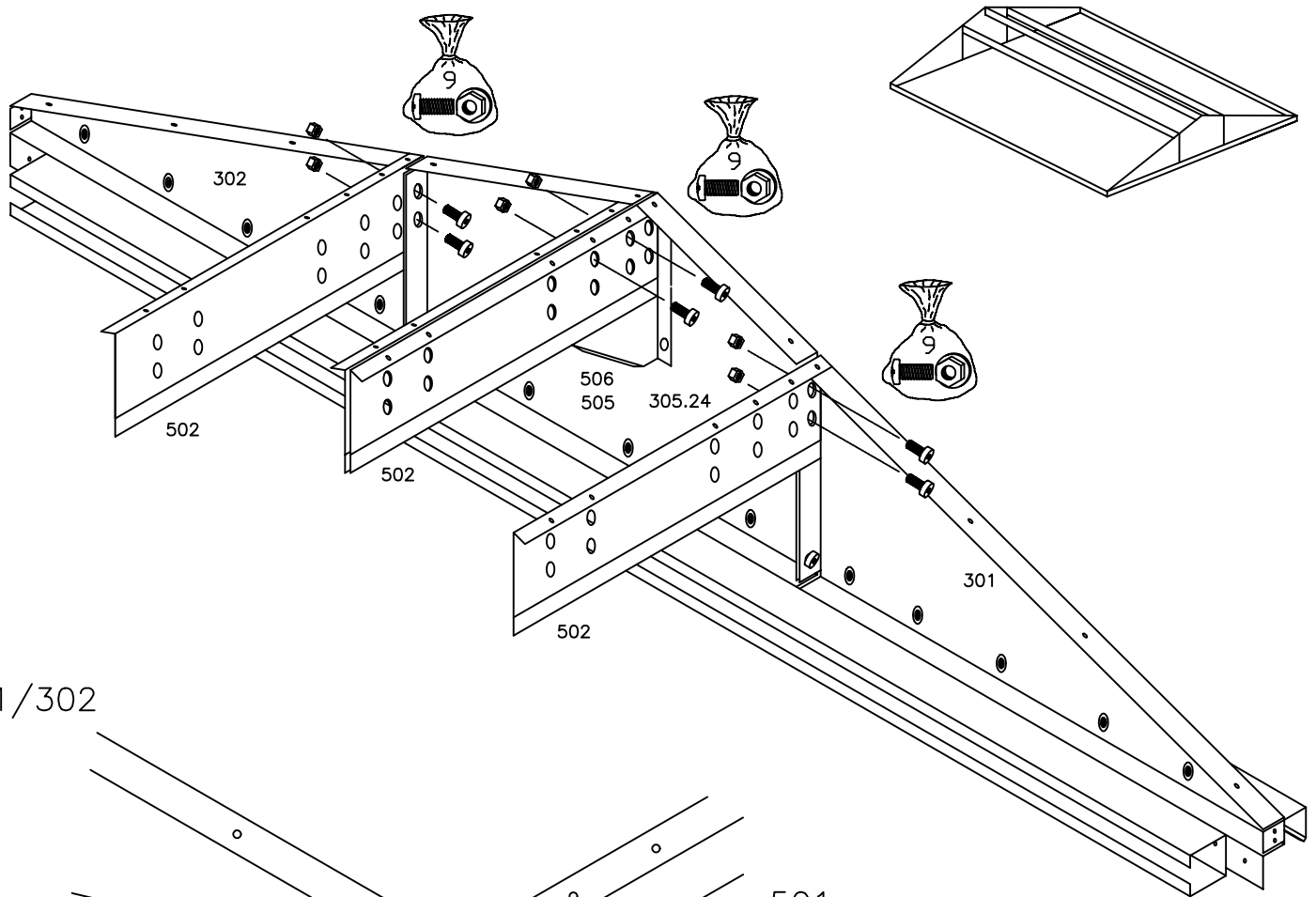

301/302

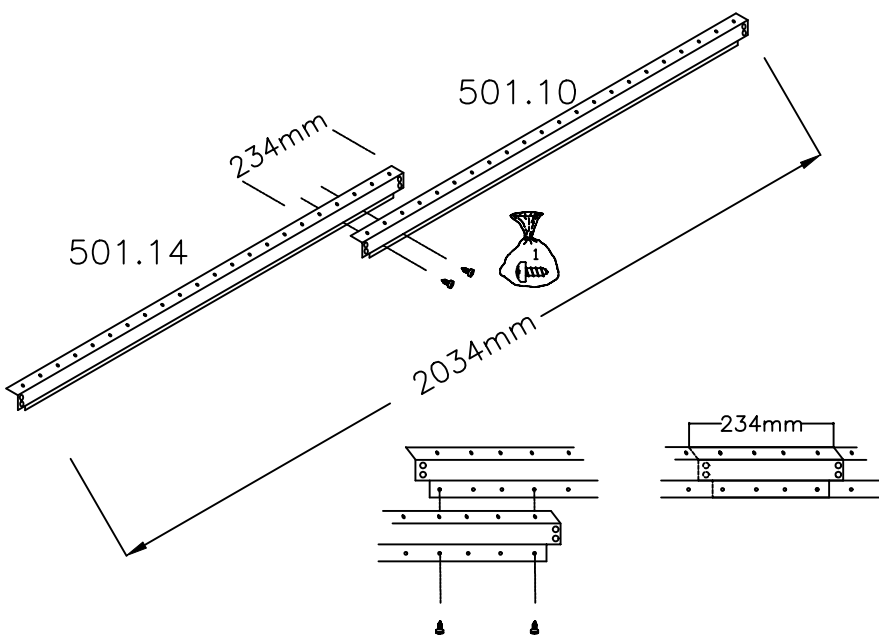
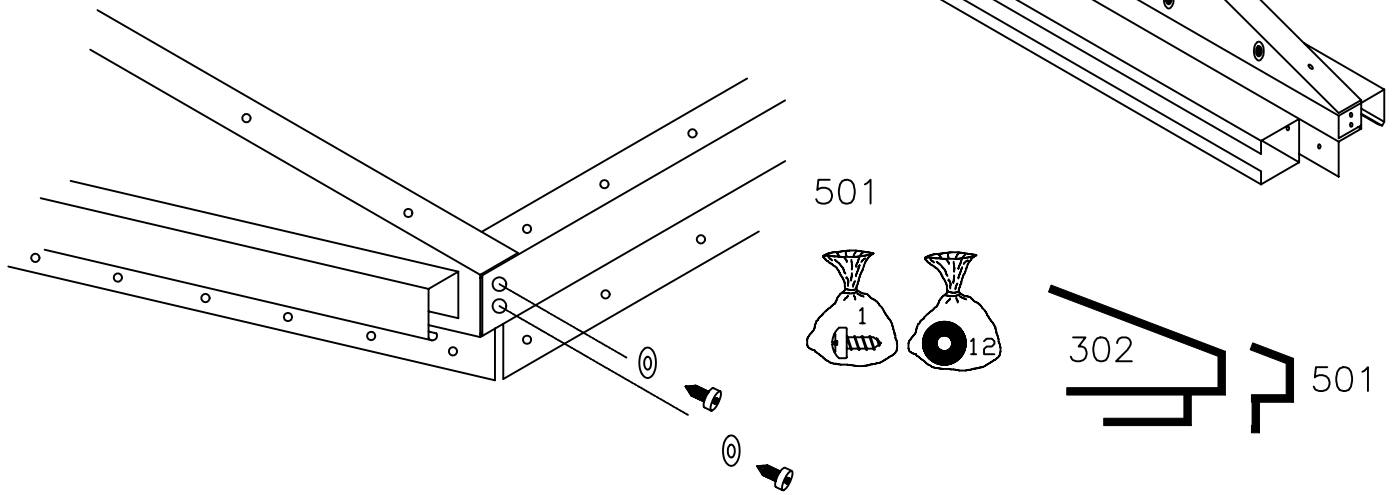

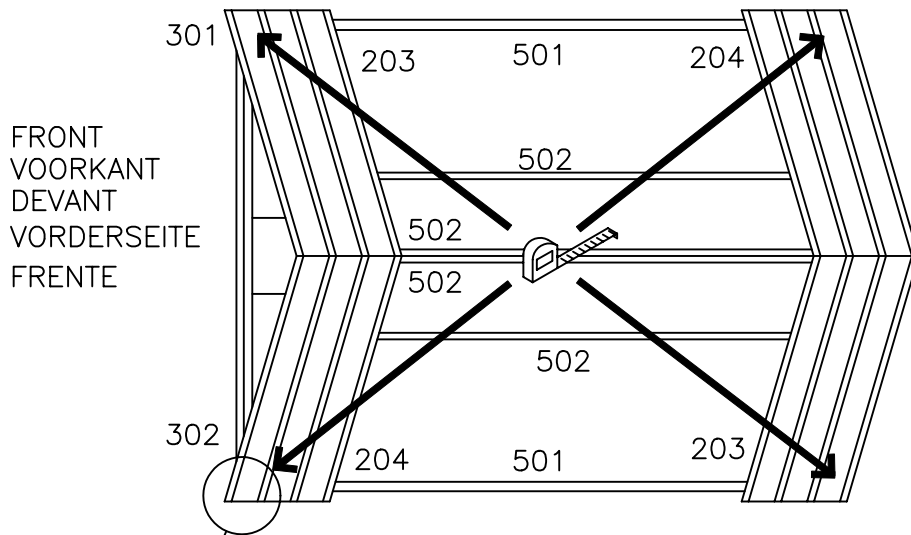
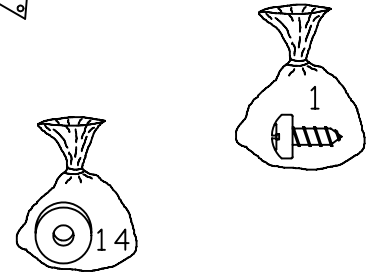
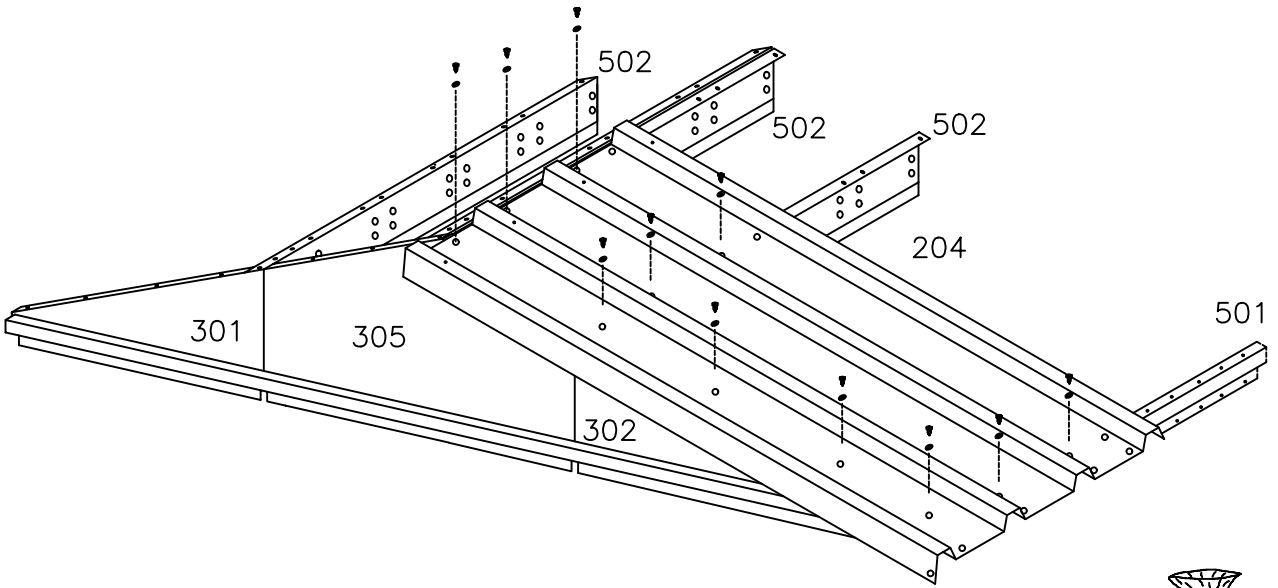

ENSURE ROOF FRAME IS "SQUARE" BEFORE SECURING PANELS

EQUARREZ LE METIER AVANT DE FIXER LES PANNEAUX

DACHRAHMEN RECHTWINKLIG VOR DACHPLATTEN FESTZUMACHEN

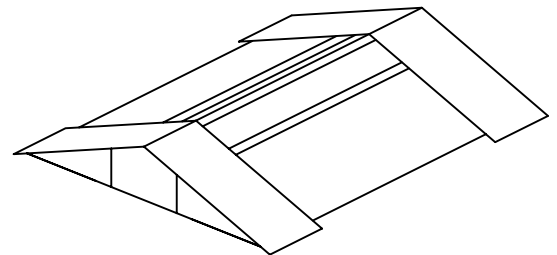
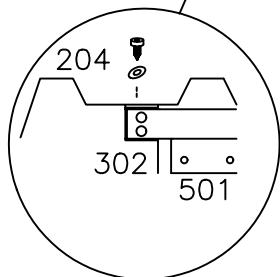

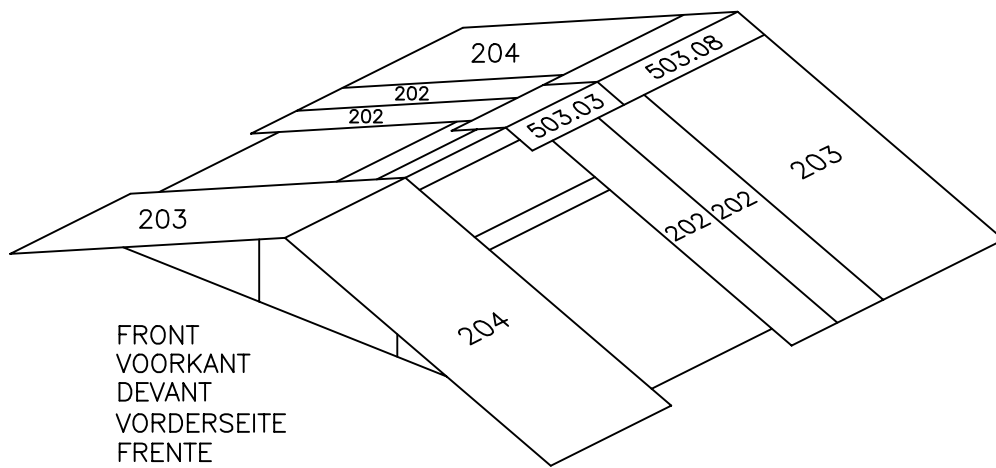
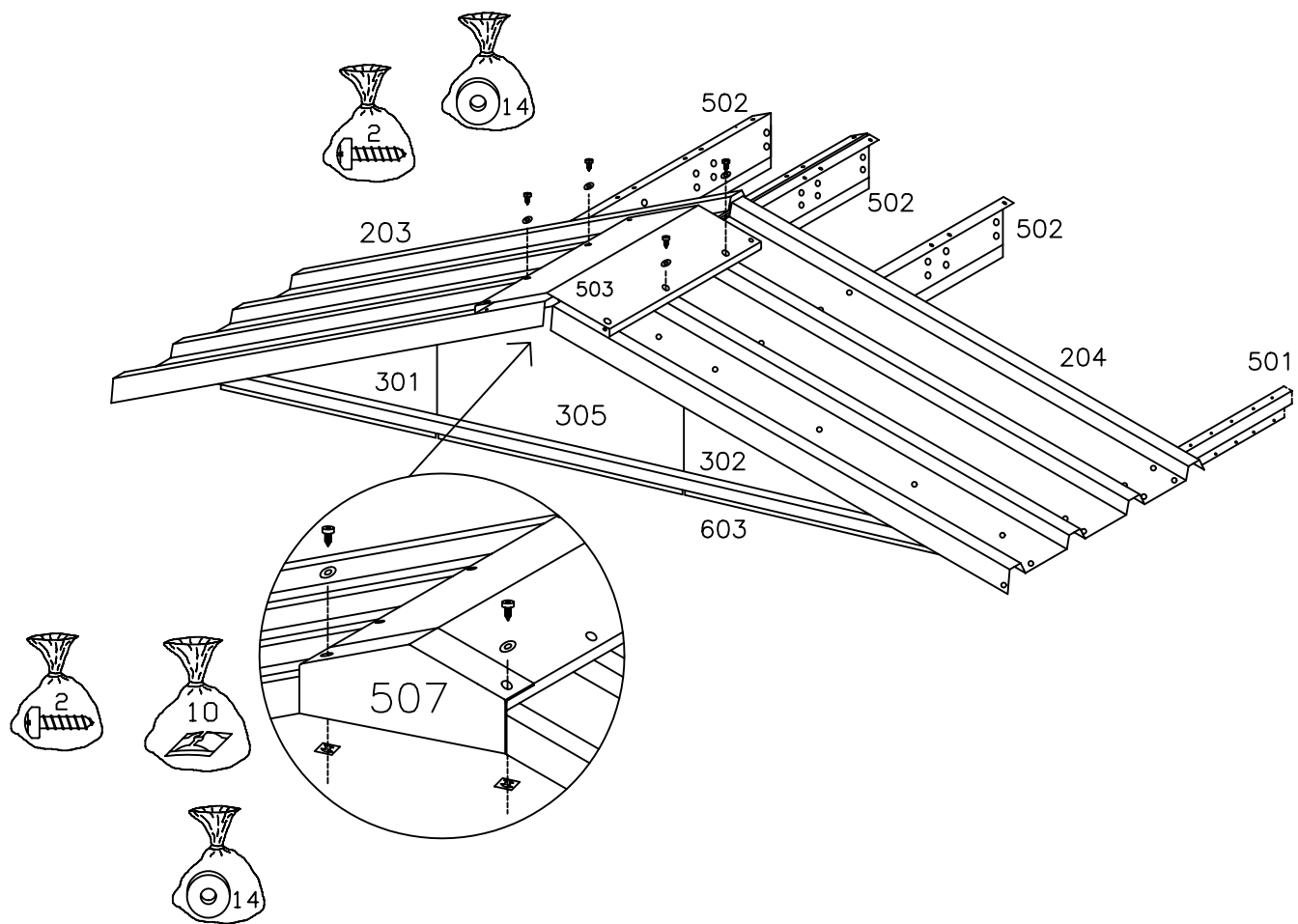

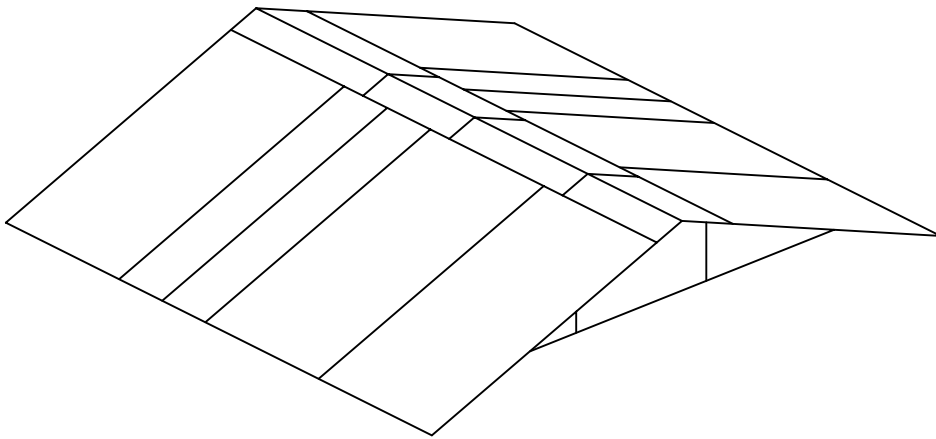
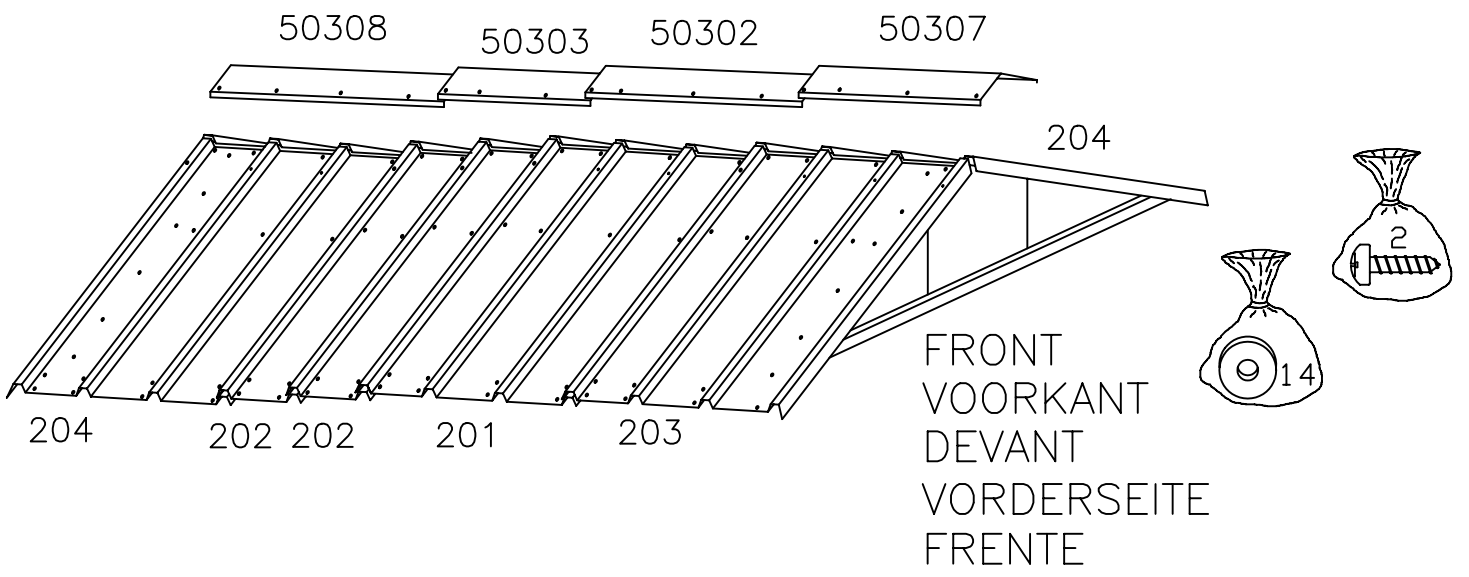

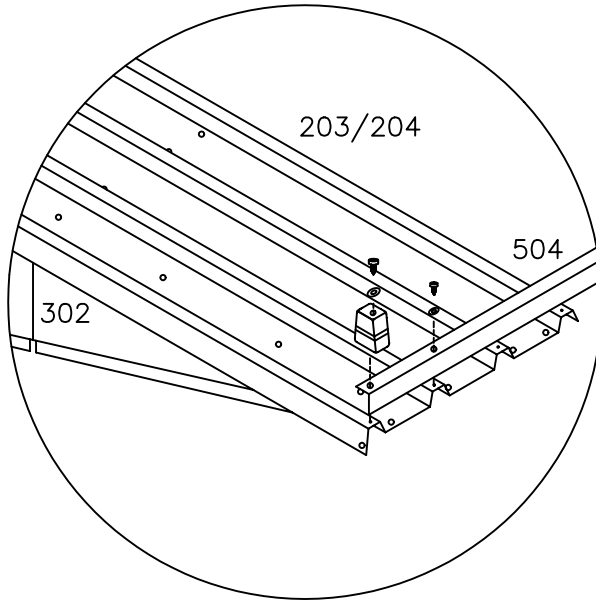
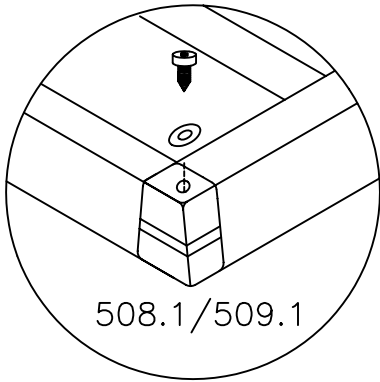

FRONT
 VOORKANT
 DEVANT
 VORDERSEITE
 FRENTE

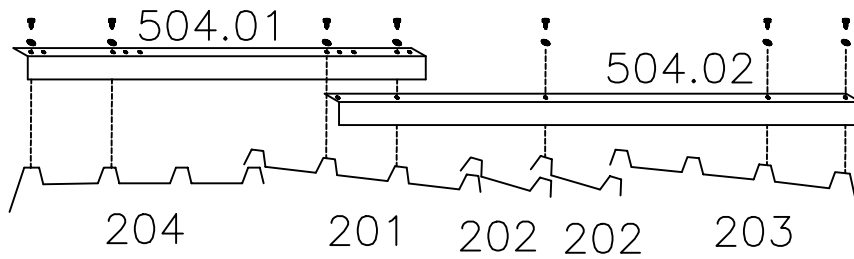
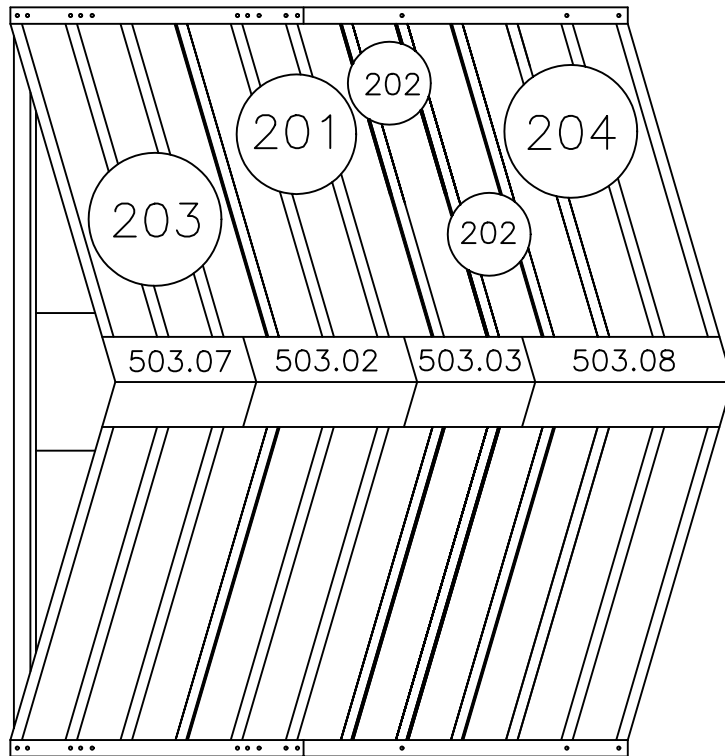

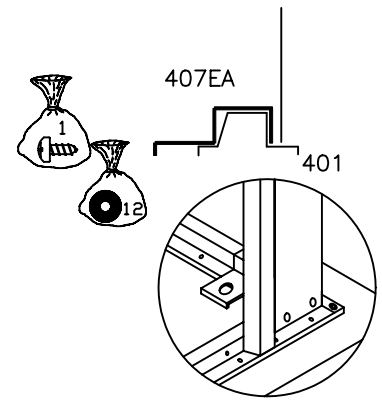
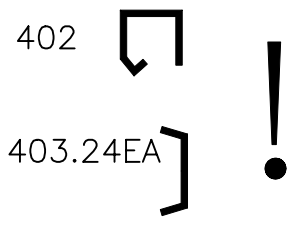
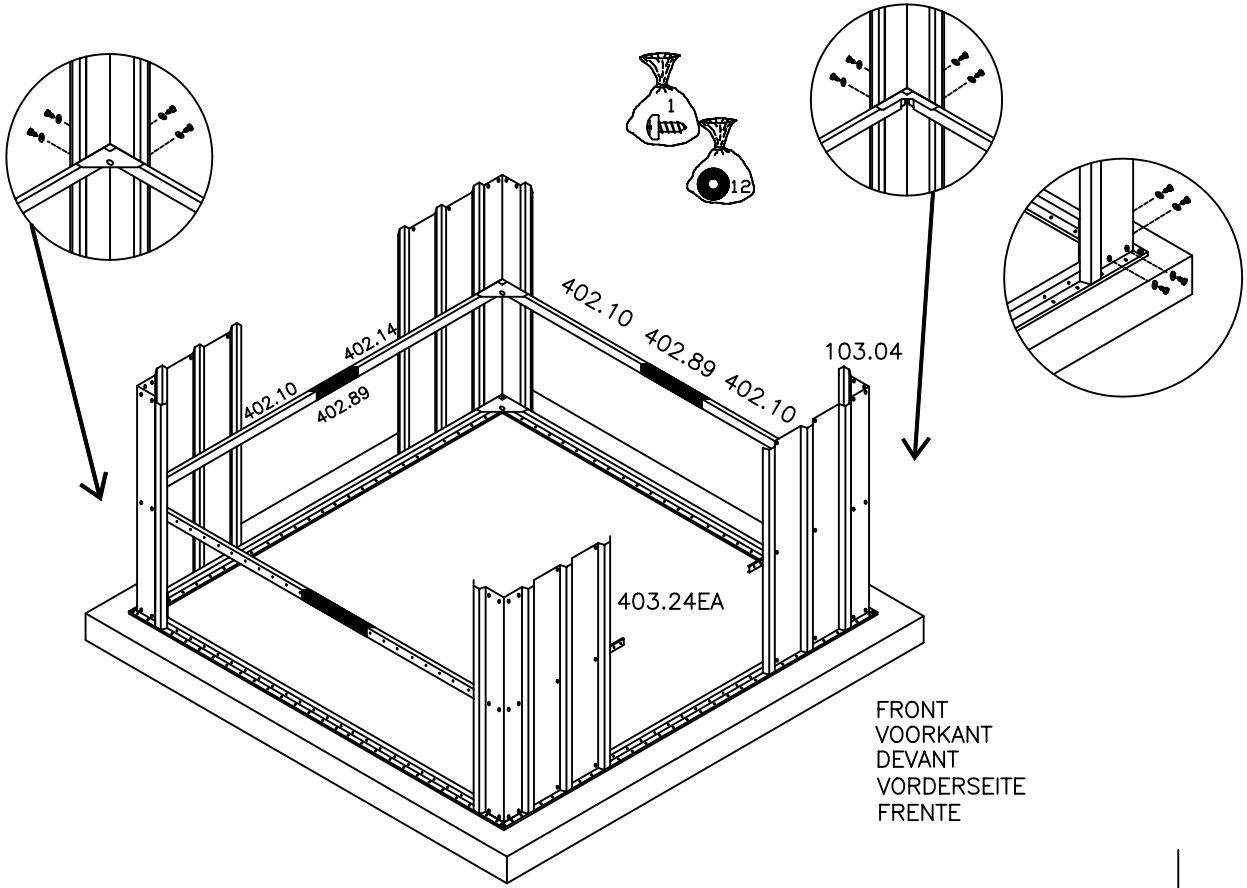
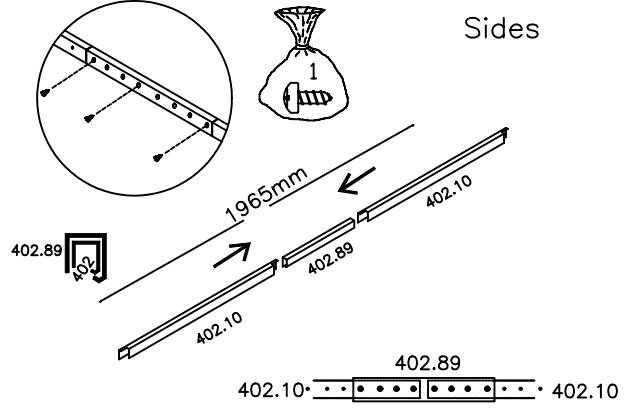
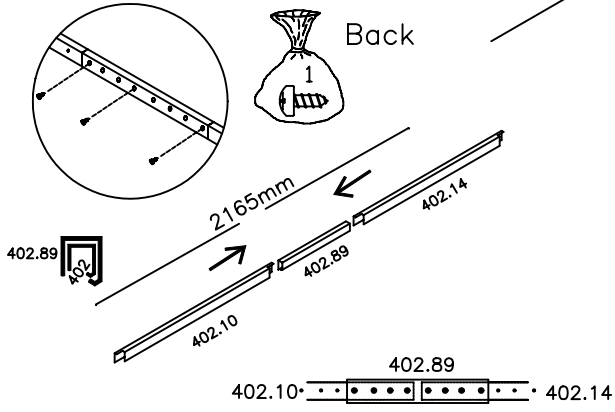
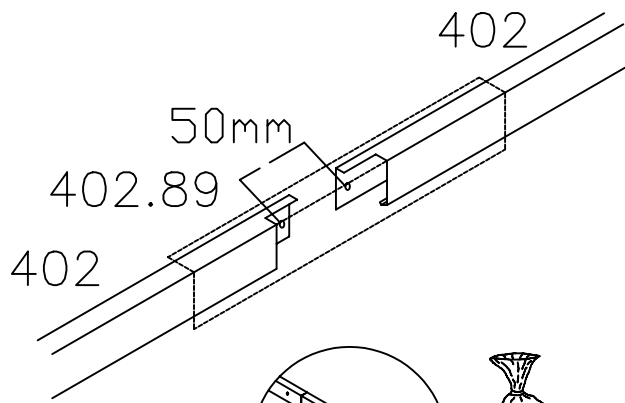

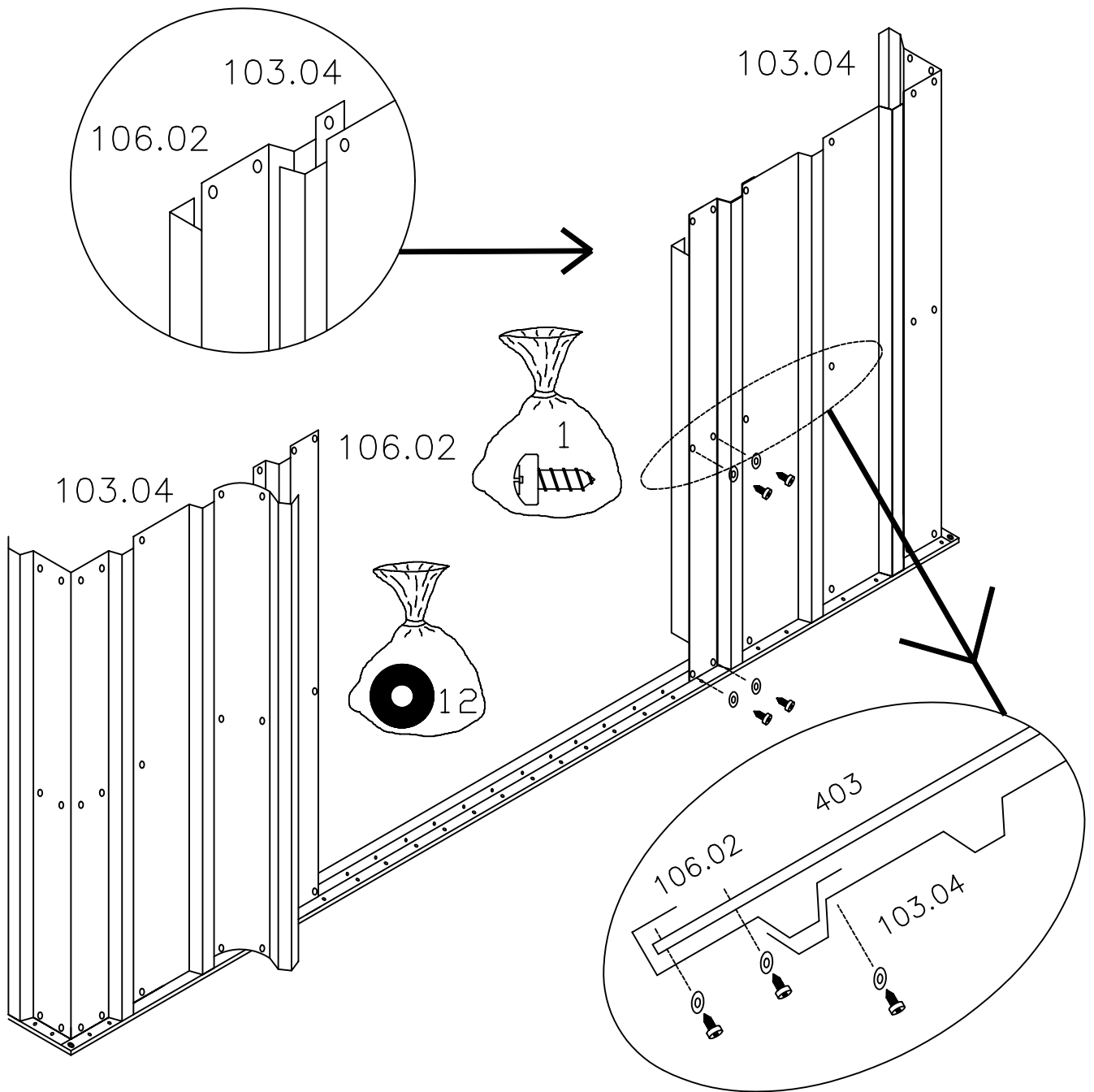

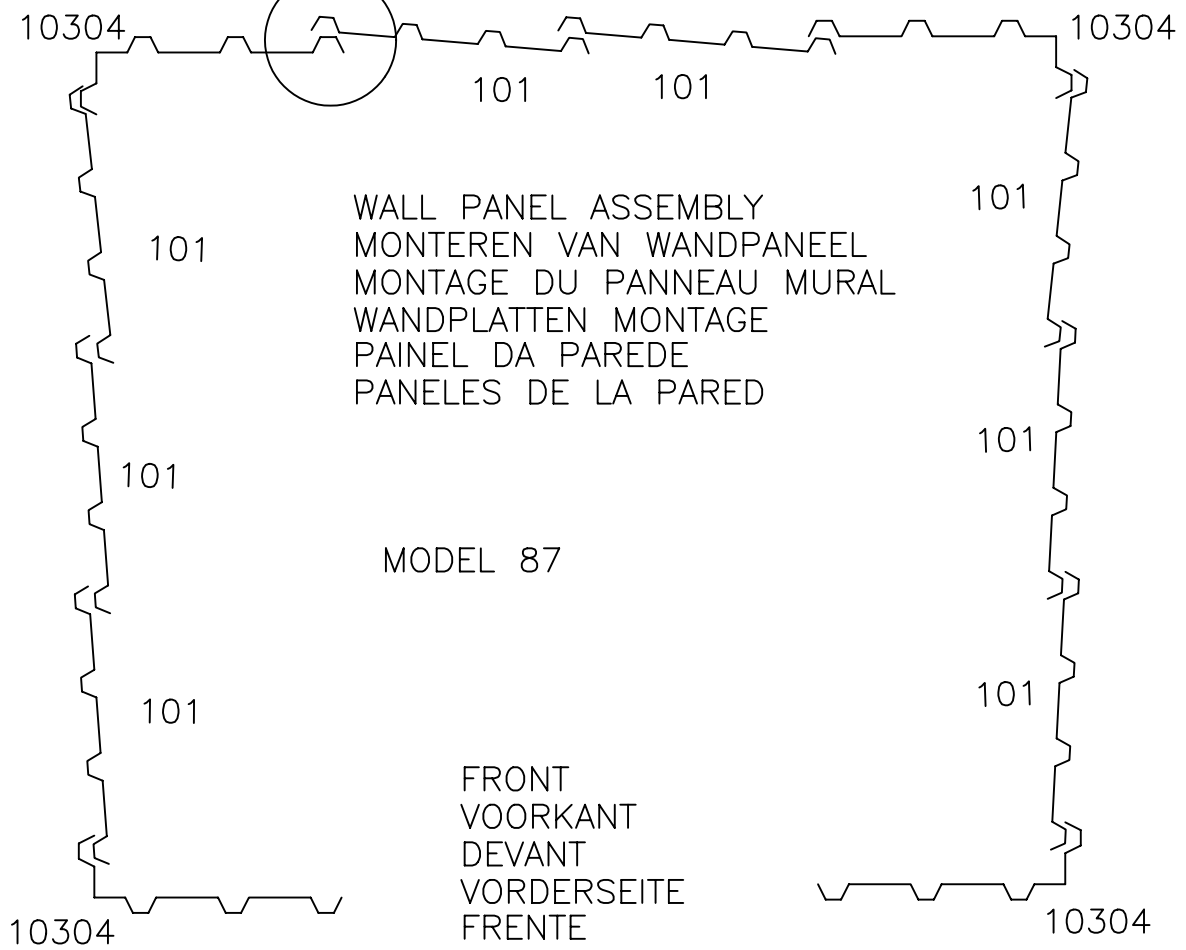
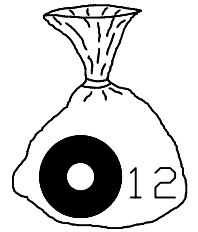
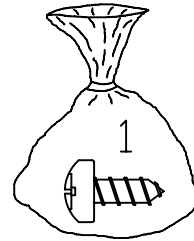
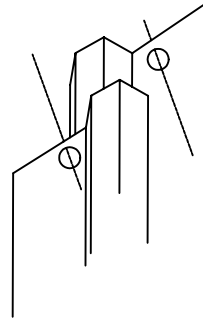
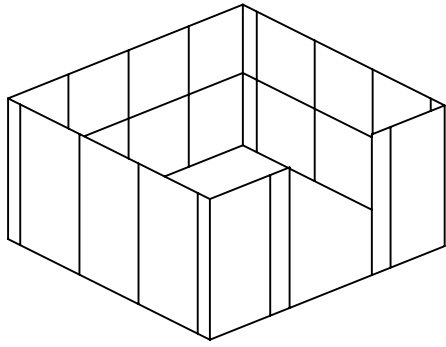

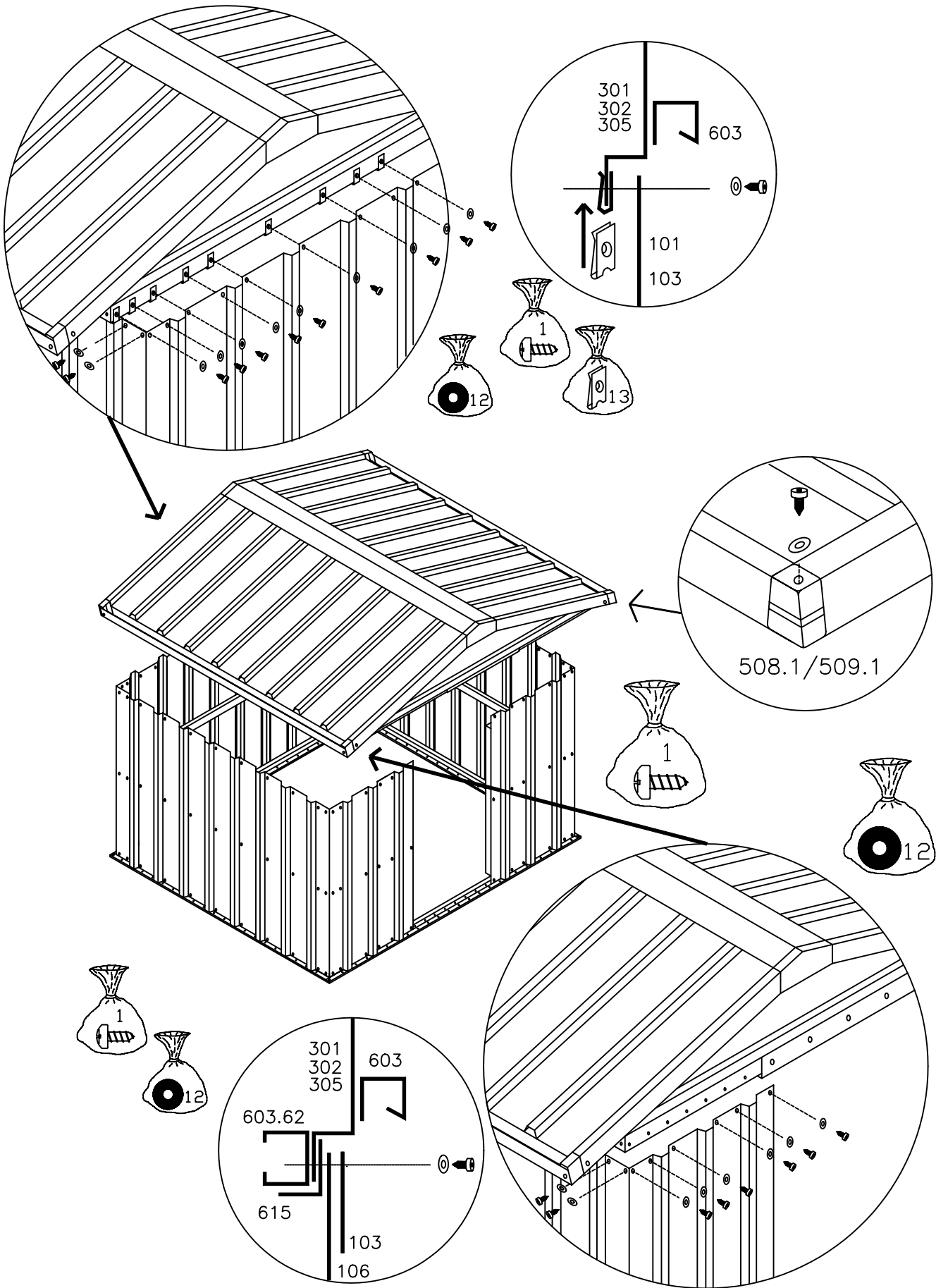

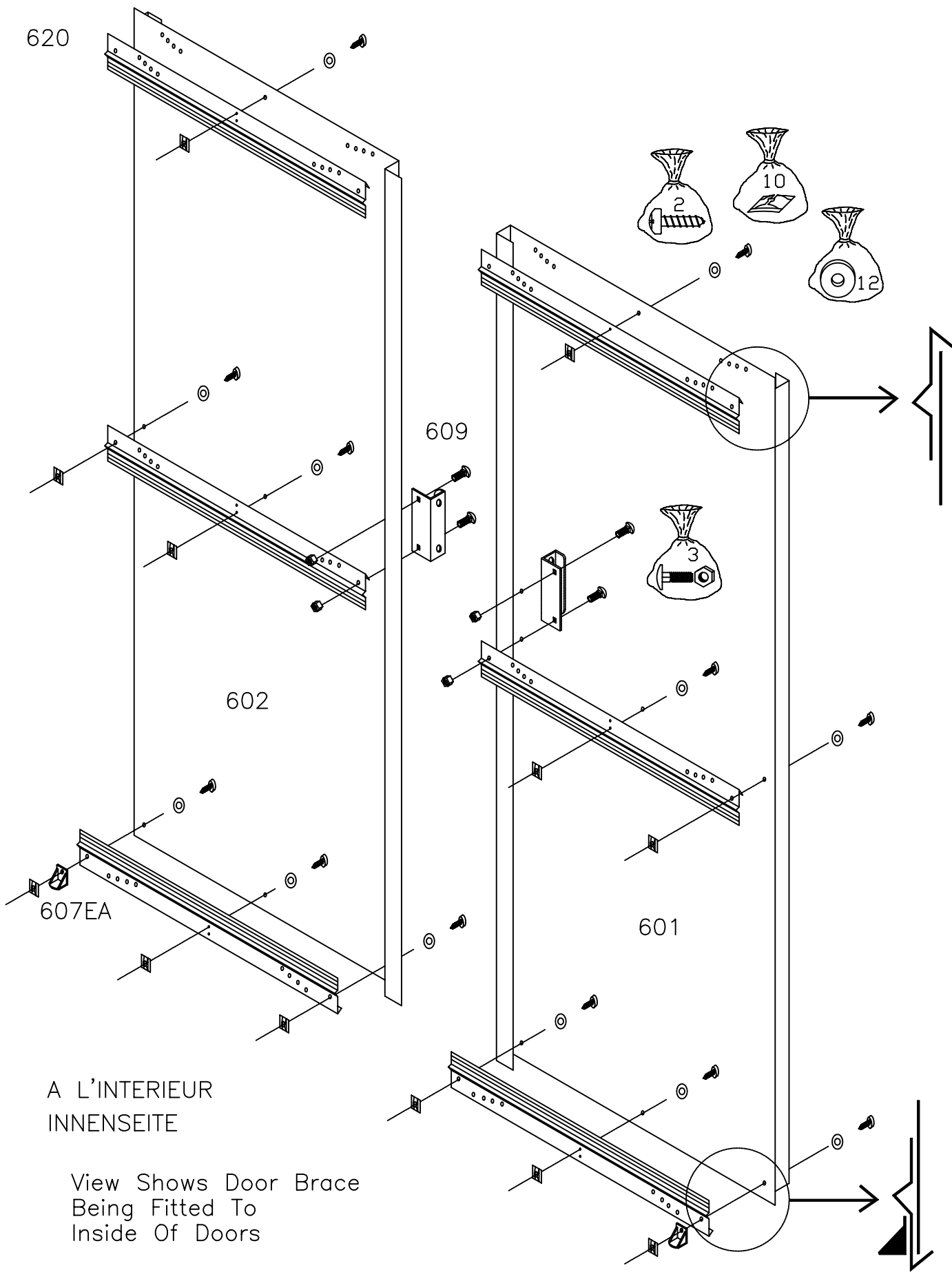

A L'INTERIEUR
INNENSEITE

View Shows Door Brace
Being Fitted To
Inside Of Doors

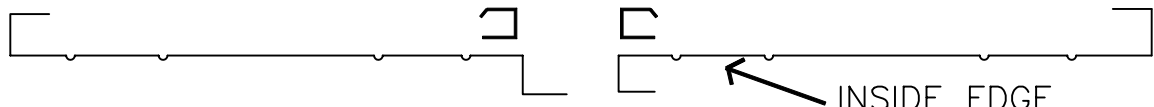

INSIDE EDGE
A L'INTERIEUR
INNENSEITE

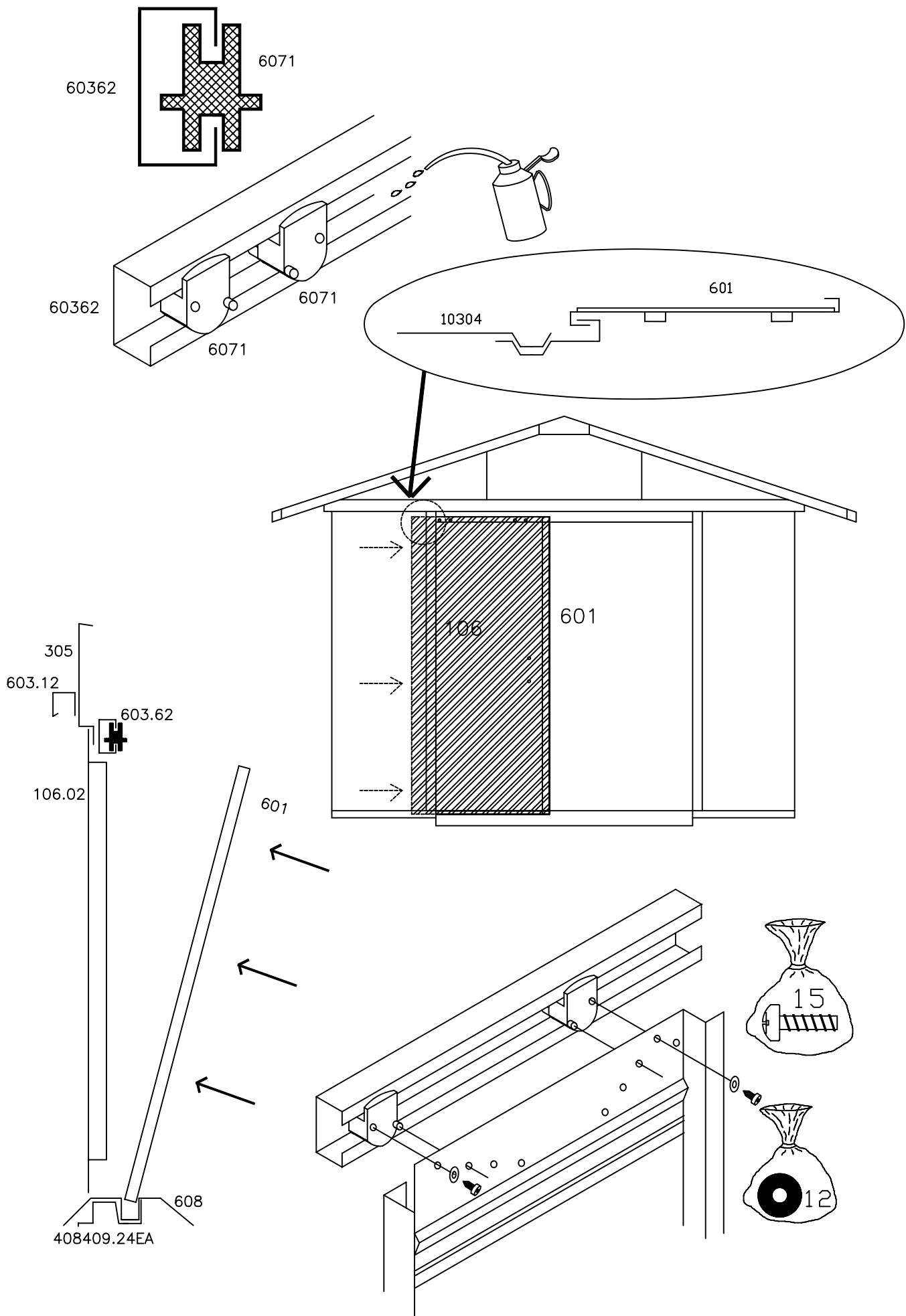

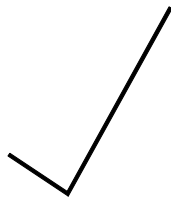
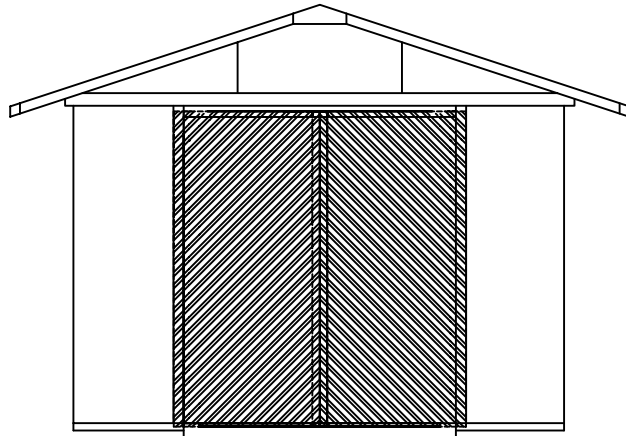
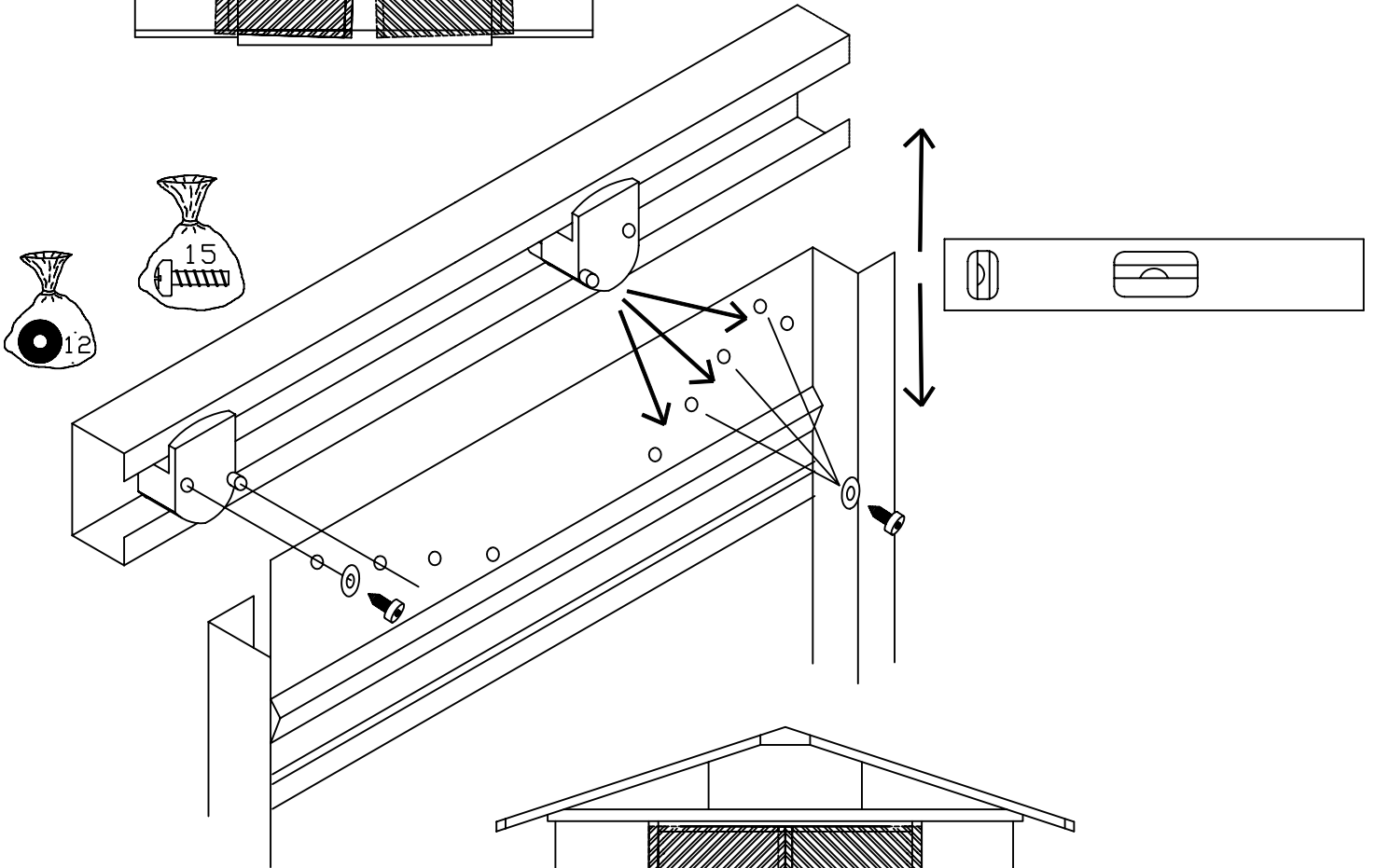
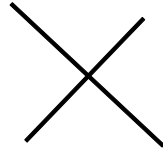
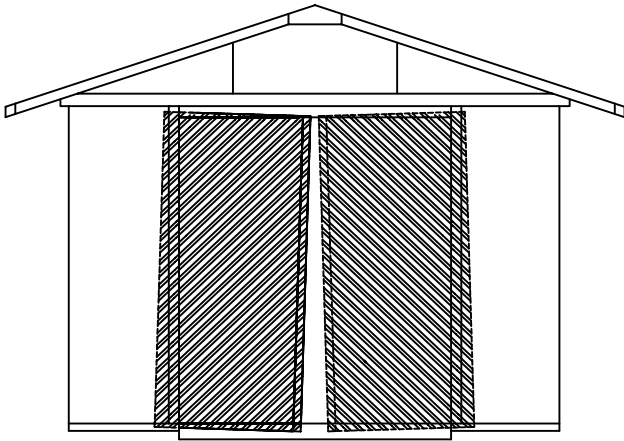

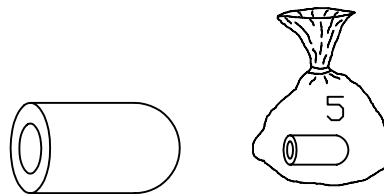
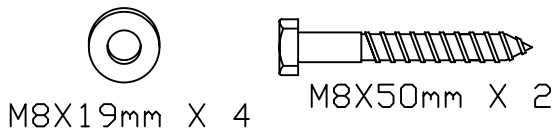
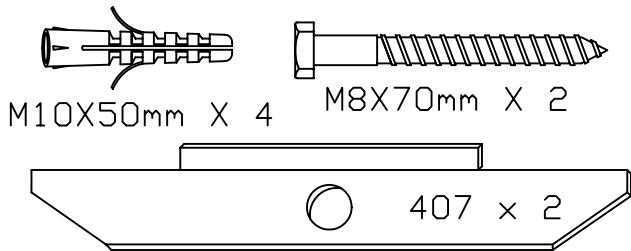
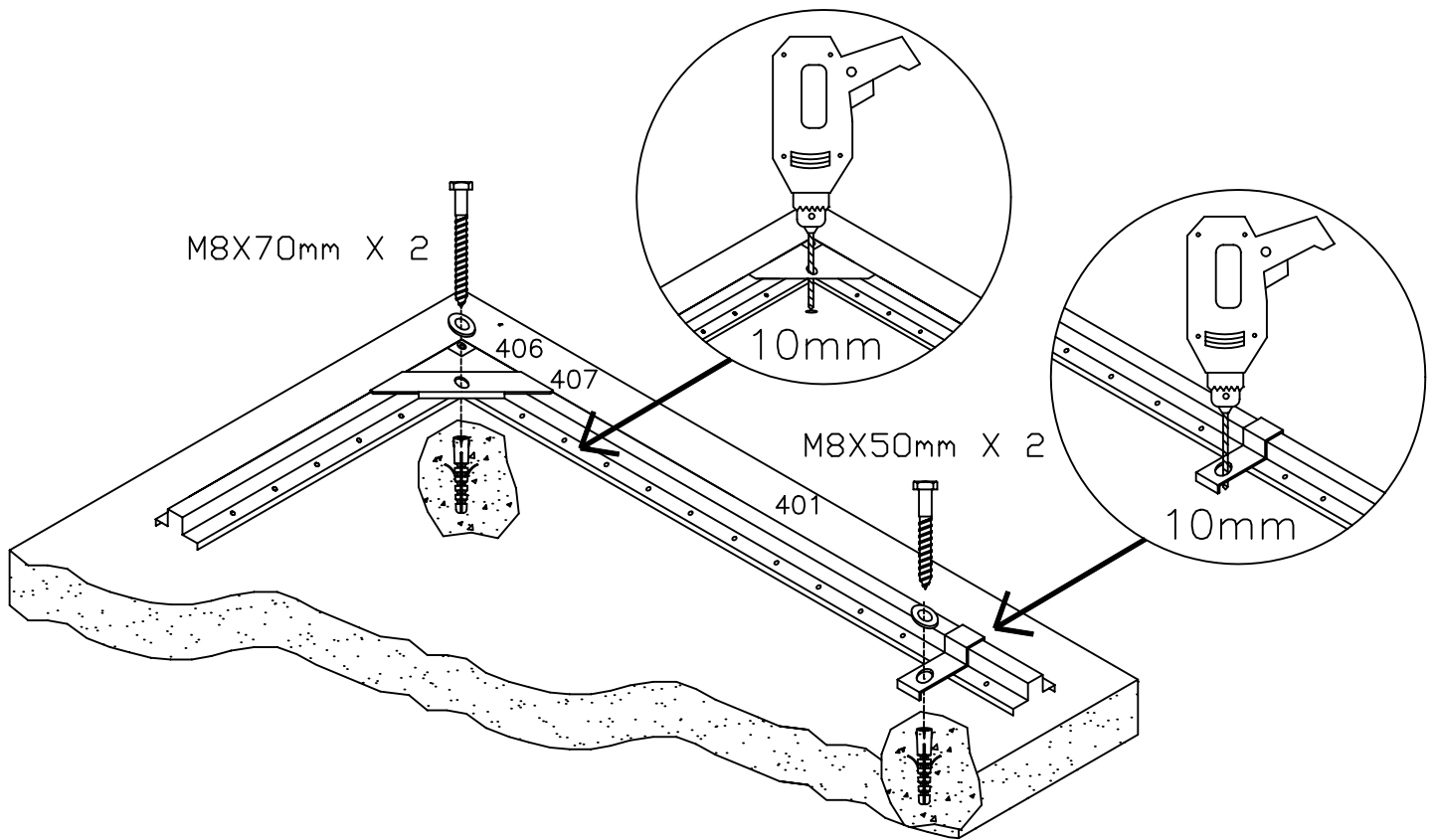

- BAG NO. 5 PLASTIC TIPS USED ON EXPOSED SCREW POINTS ON INSIDE WALLS
 SAC NO. 5 CAPUCHONS EN PLASTIQUE POUR POINTES DE VIS NUES SUR LES PAROIS INTERIEURES
 BEUTEL NO. 5 PLASTIK-AUFSTECKHUTCHEN FUR DIE SCHRAUBENSPIZTEN AN DEN INNENWANDEN
 ZAK NO. 5 PLASTIC DOPJES VOOR SCHROEFUITEINDEN AAN DE BINNENWAND
 BOLSA NO. 5 TAPONES DE PLASTICO PARA UTILIZAR EN PUNTOS DONDE QUEDE EXPUESTO EL TORNILLO EN LAS PAREDES INTERIORES
 SACO NO. 5 PONTEIRAS PLASTICAS PARA PONTAS DE PARAFUSOS EXPOSTAS NAS PAREDES INTERIORES